



**SANTA CRUZ METROPOLITAN TRANSIT DISTRICT (METRO)
BOARD OF DIRECTORS AGENDA
REGULAR MEETING
AUGUST 28, 2015 – 9:00 AM
SCOTTS VALLEY CITY COUNCIL CHAMBERS
1 CIVIC CENTER DRIVE
SCOTTS VALLEY, CA 95066**

MISSION STATEMENT: “To provide a public transportation service that enhances personal mobility and creates a sustainable transportation option in Santa Cruz County through a cost-effective, reliable, accessible, safe, clean and courteous transit service.”

The Board Meeting Agenda Packet can be found online at www.SCMTD.com and is available for inspection at Santa Cruz Metro’s Administrative offices at 110 Vernon Street, Santa Cruz, California.

This document has been created with accessibility in mind. With the exception of the Structural Deficit Workshop materials, certain 3rd party and other attachments, it passes the Adobe Acrobat XI Accessibility Full Check. If you have any questions about the accessibility of this document, please email your inquiry to accessibility@scmttd.com

BOARD ROSTER

Director Ed Bottorff	City of Capitola
Director Dene Bustichi, Chair	City of Scotts Valley
Director Karina Cervantez	City of Watsonville
Director Cynthia Chase	City of Santa Cruz
Director Jimmy Dutra	City of Watsonville
Director Zach Friend	County of Santa Cruz
Director Donald “Norm” Hagen	County of Santa Cruz
Director Don Lane	City of Santa Cruz
Director John Leopold	County of Santa Cruz
Director Bruce McPherson	County of Santa Cruz
Director Mike Rotkin, Vice Chair	County of Santa Cruz
Ex-Officio Director Donna Blitzer	UC Santa Cruz
Alex Clifford	METRO CEO/General Manager
Leslyn K. Syren	METRO District Counsel

TITLE 6 - INTERPRETATION SERVICES / TÍTULO 6 - SERVICIOS DE TRADUCCIÓN

Spanish language interpretation and Spanish language copies of the agenda packet are available on an as-needed basis. Please make advance arrangements with the Executive Assistant at 831-426-6080. Interpretación en español y traducciones en español del paquete de la agenda están disponibles sobre una base como-necesaria. Por favor, hacer arreglos por adelantado con Coordinador de Servicios Administrativos al numero 831-426-6080.

AMERICANS WITH DISABILITIES ACT

The Board of Directors meets in an accessible facility. Any person who requires an accommodation or an auxiliary aid or service to participate in the meeting, or to access the

agenda and the agenda packet (including a Spanish language copy of the agenda packet), should contact the Executive Assistant, at 831-426-6080 as soon as possible in advance of the Board of Directors meeting. Hearing impaired individuals should call 711 for assistance in contacting Santa Cruz METRO regarding special requirements to participate in the Board meeting. For information regarding this agenda or interpretation services, please call Santa Cruz METRO at 831-426-6080.

SECTION I: OPEN SESSION

NOTE: THE BOARD CHAIR MAY TAKE ITEMS OUT OF ORDER

1 CALL TO ORDER

2 ROLL CALL

3 ANNOUNCEMENTS

- 3-1. Spanish language interpretation will be available during "Oral Communications" and for any other agenda item for which these services are needed.
- 3-2. Today's meeting is being broadcast by Community Television of Santa Cruz County.

4 COMMUNICATIONS TO THE BOARD OF DIRECTORS

This time is set aside for Directors and members of the general public to address any item not on the Agenda which is within the subject matter jurisdiction of the Board. No action or discussion shall be taken on any item presented except that any Director may respond to statements made or questions asked, or may ask questions for clarification. All matters of an administrative nature will be referred to staff. All matters relating to Santa Cruz METRO will be noted in the minutes and may be scheduled for discussion at a future meeting or referred to staff for clarification and report. Any Director may place matters brought up under Communications to the Board of Directors on a future agenda. In accordance with District Resolution 69-2-1, speakers appearing at a Board meeting shall be limited to three minutes in his or her presentation. Any person addressing the Board may submit written statements, petitions or other documents to complement his or her presentation. When addressing the Board, the individual may, but is not required to, provide his/her name and address in an audible tone for the record.

5 WRITTEN COMMUNICATIONS FROM MAC

6 LABOR ORGANIZATION COMMUNICATIONS

7 ADDITIONAL DOCUMENTATION TO SUPPORT EXISTING AGENDA ITEMS

CONSENT AGENDA

All items appearing on the Consent Agenda are recommended actions which are considered to be routine and will be acted upon as one motion. All items removed will be considered later in the agenda. The Board Chair will allow public input prior to the approval of the Consent Agenda items.

- 8-01 ACCEPT AND FILE MINUTES OF THE SANTA CRUZ METRO BOARD OF DIRECTORS REGULAR MEETING OF AUGUST 14, 2015**
Alex Clifford, CEO/General Manager
- 8-02 ACCEPT AND FILE MINUTES FOR THE METRO ADVISORY COMMITTEE (MAC) MEETING OF JUNE 17, 2015**
Alex Clifford, CEO/General Manager
- 8-03 ACCEPT AND FILE SANTA CRUZ METRO SYSTEM RIDERSHIP REPORTS FOR THE MONTH OF JUNE 2015 AND THE END OF FY15**
Carolyn Derwing, Schedule Analyst/Acting Planner
- 8-04 ACCEPT AND FILE STATUS REPORT OF ACTIVE GRANTS AND SUBMITTED GRANT PROPOSALS FOR AUGUST 2015**
Tom Hiltner, Acting Planning and Development Manager
- 8-05 ACCEPT AND FILE SANTA CRUZ COUNTY REGIONAL TRANSPORTATION COMMISSION (SCCRTC) MEETING MINUTES REFLECTING VOTING RESULTS FROM SANTA CRUZ METRO APPOINTEES**
Alex Clifford, CEO/General Manager
- 8-06 CONSIDERATION OF METROBASE MONTHLY CHANGE ORDER REPORT**
Andrew Kreck, Project Manager, Hill International
- 8-07 RENEWAL OF PROPERTY INSURANCE COVERAGE FOR FY16 WITH ZURICH AMERICAN INSURANCE COMPANY**
Angela Aitken, Finance Manager
- 8-08 CONSIDERATION OF AUTHORIZING THE CEO TO EXECUTE A CONTRACT EXTENSION WITH AIRTEC SERVICE FOR HVAC MAINTENANCE SERVICES, INCREASING THE CONTRACT TOTAL BY \$22,000**
Al Pierce, Maintenance Manager
- 8-09 CONSIDERATION OF ISSUING A FORMAL INVITATION FOR BIDS FOR PURCHASE AND INSTALLATION OF ANTI-CLIMB FENCING PANELS AT THE NEW OPERATIONS FACILITY**
Liseth Guizar, Safety, Security and Risk Manager
- 8-10 RECEIVE A SEMI-ANNUAL REPORT ON THE STATUS OF METRO'S DISADVANTAGED BUSINESS ENTERPRISE PROGRAM**
Angela Aitken, DBE Liaison Officer

- 8-11 CONSIDERATION OF ISSUING A FORMAL REQUEST FOR PROPOSALS FOR STATE LEGISLATIVE REPRESENTATIVE SERVICES**
Alex Clifford, CEO/General Manager
- 8-12 CONSIDERATION OF ISSUING A FORMAL REQUEST FOR PROPOSALS FOR FEDERAL LEGISLATIVE REPRESENTATIVE SERVICES**
Alex Clifford, CEO/General Manager
- 8-13 EXTENSION OF PROVISIONAL EMPLOYMENT**
Robyn D. Slater, HR Manager
- 8-14 CONSIDERATION OF ISSUING A FORMAL REQUEST FOR PROPOSALS FOR PURCHASE OF A FINANCIAL SOFTWARE SYSTEM & MAINTENANCE OPTIONS**
Angela Aitken, Finance Manager
- 8-15 CONSIDERATION OF PROVISION OF A BUS, PARACRUZ VEHICLE AND OPERATOR TO SUPPORT THE UNITED TRANSPORTATION UNION LOCAL 23 SENIOR LUNCHEON**
Anna Marie Gouveia, Fixed Route Superintendent
- 8-16 CONSIDERATION OF APPROVAL OF A REVISED CLASS SPECIFICATION FOR THE PLANNING AND DEVELOPMENT MANAGER**
Robyn D. Slater, HR Manager
- 8-17 CONSIDERATION OF AUTHORIZING THE CEO/GENERAL MANAGER TO EXECUTE A ONE-YEAR EXTENSION AMENDMENT TO THE CONTRACT FOR TRANSIT SERVICES WITH THE UNIVERSITY OF CALIFORNIA SANTA CRUZ (UCSC) BEGINNING SEPTEMBER 1, 2015**
Erich Friedrich, Sr. Transportation Planner
- 8-18 LEADERSHIP SANTA CRUZ CLASS #31**
Alex Clifford, CEO/General Manager
- 8-19 CONSIDERATION OF APPROVING REVISIONS TO METRO'S PARACRUZ CUSTOMER GUIDE**
April Warnock, Paratransit Superintendent

REGULAR AGENDA

- 9 **PRESENTATION OF EMPLOYEE LONGEVITY AWARDS FOR FRANCISCO F. ESTRADA, JOHN THOMAS, ANDREW HILL, DARRYL S. JUAN, MANUEL MARTINEZ, ERRON ALVEY, LISETH GUIZAR, MARISELA MENDOZA, SHAWN O'DONNELL**
Chair Dene Bustichi
- 10 **RESOLUTION OF APPRECIATION FOR KEVIN WALTER**
Chair Dene Bustichi
- 11 **INTRODUCTION OF NEW OPERATOR GRADUATING CLASS**
Anna Marie Gouveia, Fixed Route Superintendent
- 12 **CONSIDERATION TO ADOPT THE BUS STOP GUIDE**
Erich Friedrich, Sr. Transportation Planner
- 13 **INFORMATION TECHNOLOGY (IT) STAFF RESTRUCTURE**
Isaac Holly, IT Manager
- 14 **ORAL REPORT ON PEPRA 13(c)**
Leslyn Syren, General Counsel
- 15 **CEO TO GIVE ORAL REPORT**
Alex Clifford, CEO/General Manager
- 16 **ANNOUNCEMENT OF NEXT MEETING: FRIDAY, SEPTEMBER 25, 2015 AT 8:30 AM, WATSONVILLE CITY CHAMBERS, 275 MAIN STREET, WATSONVILLE**
Chair Dene Bustichi
- 17 **RECESS TO CLOSED SESSION**

SECTION II: CLOSED SESSION

1. **CONFERENCE WITH LEGAL COUNSEL – ANTICIPATED LITIGATION**
Significant exposure to litigation pursuant to subdivision (c) of Government Code Section 54956.9: 2 cases

SECTION III: RECONVENE TO OPEN SESSION

- 18 **REPORT OF CLOSED SESSION ITEMS**
Leslyn Syren, General Counsel
- 19 **ADJOURNMENT**
Chair Dene Bustichi

Pursuant to Section 54954.2(a)(1) of the Government Code of the State of California, this agenda was posted at least 72 hours in advance of the scheduled meeting at a public place freely accessible to the public 24 hours a day. The agenda packet and materials related to an item on this Agenda submitted to the Board of Directors after distribution of the agenda packet are available for public inspection in the Santa Cruz METRO Administrative Office (110 Vernon Street, Santa Cruz) during normal business hours. Such documents are also available on the Santa Cruz METRO website at www.scmtd.com subject to staff's ability to post the document before the meeting.



DATE: August 28, 2015

TO: Board of Directors

FROM: Alex Clifford, CEO

**SUBJECT: ACCEPT AND FILE MINUTES OF THE SANTA CRUZ METRO BOARD
OF DIRECTORS REGULAR MEETING OF AUGUST 14, 2015**

I. RECOMMENDED ACTION

That the Board of Directors Accept and File the Minutes for the Santa Cruz Metropolitan Transit District (METRO) Regular Board of Directors Meeting of August 14, 2015

- Staff is providing minutes from the Santa Cruz Metropolitan Transit District (METRO) Board of Directors Regular Meeting of August 14, 2015
- Each meeting, staff will provide minutes from the previous METRO Board of Directors meeting

II. DISCUSSION/BACKGROUND

The Board requested that staff include, in the Board Packet, minutes for previous METRO Board of Directors meetings. Staff is enclosing the minutes from these meetings as a mechanism of complying with this request.

III. FINANCIAL CONSIDERATIONS/IMPACT

None

IV. ALTERNATIVES CONSIDERED

None

V. ATTACHMENTS

Attachment A: Draft minutes for the Regular Board of Directors Meeting of August 14, 2015

Prepared by: Gina Pye, Executive Assistant

VI. APPROVALS:

Alex Clifford, CEO/General Manager

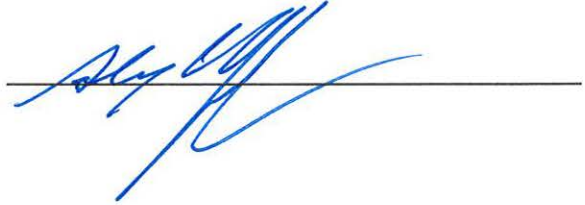

Attachment A



**SANTA CRUZ METROPOLITAN TRANSIT DISTRICT
BOARD OF DIRECTORS MEETING MINUTES
REGULAR MEETING
AUGUST 14, 2015 – 8:30 AM
SANTA CRUZ METRO ADMIN OFFICES
110 VERNON STREET
SANTA CRUZ, CA 95060**

A regular meeting of the Board of Directors of the Santa Cruz Metropolitan Transit District (METRO) was convened on Friday, August 14, 2015, at METRO's Admin Offices at 110 Vernon Street, Santa Cruz, California.

The Board Meeting Agenda Packet can be found online at www.SCMTD.com and is available for inspection at Santa Cruz METRO's Administrative offices at 110 Vernon Street, Santa Cruz, California.

This document has been created with accessibility in mind. This document passes the Adobe Acrobat XI Accessibility Full Check. If you have any questions about the accessibility of this document, please email your inquiry to accessibility@scmttd.com

SECTION I: OPEN SESSION

1 CALL TO ORDER at 8:34A by Vice Chair Rotkin

2 ROLL CALL: The following Directors were **present:**

Director Ed Bottorff	City of Capitola
Director Dene Bustichi, Chair	City of Scotts Valley
Director Cynthia Chase	City of Santa Cruz
Director Jimmy Dutra	City of Watsonville
Director Zach Friend	County of Santa Cruz
Director D. Norm Hagen	County of Santa Cruz
Director Don Lane	City of Santa Cruz
Director John Leopold	County of Santa Cruz
Director Bruce McPherson	County of Santa Cruz
Director Mike Rotkin, Vice Chair	County of Santa Cruz

The following Directors were absent:

Ex-Officio Director Donna Blitzer	UC Santa Cruz
Director Karina Cervantez	City of Watsonville

STAFF PRESENT:

Alex Clifford, CEO
Leslyn Syren, General Counsel

DRAFT

8-01A.1

Attachment A

METRO EMPLOYEES AND MEMBERS OF THE PUBLIC WHO VOLUNTARILY INDICATED THEY WERE PRESENT (IN ALPHABETICAL ORDER) WERE:

Angela Aitken, METRO
Carolyn Derwing, METRO
Paul Hiepling, AMBAG
Sachi Itagaki, SVWD
Debbie Kinslow, METRO
M.W. Regan, VMU, SEIU

Gloria Rovay, Riders with ParaCruz
Suzanne Silva, METRO
Robyn Slater, METRO
April Warnock, METRO
Daniel Zaragoza, METRO

3 ANNOUNCEMENTS

Vice Chair Rotkin announced the following had been distributed at each Director's seat:

- (CONFIDENTIAL) Updated Board Contact Card
- Updated METRO Org Chart
- Legislative Update (Federal and State)

He also announced that copies of the following were distributed to each Director with additional copies available at the sign-in table:

- "Are You MAC Material?" pamphlet
- August 7, 2015 letter from ParaCruz regarding changes effective September 10, 2015
- August 11, 2015 letter from Santa Cruz Chamber of Commerce re Support for Transit Funding
- Headways for the period July 2 – September 9, 2015

4 COMMUNICATIONS TO THE BOARD OF DIRECTORS

Vice Chair Rotkin opened the floor to public comment

Hearing no public comment, the meeting continued to the next agenda item.

5 LABOR ORGANIZATION COMMUNICATIONS

Vice Chair Rotkin opened the floor to public comment.

Union representatives, Eduardo Montesino, Manny Martinez and Carolyn Derwing, each welcomed the Board back into session after the July break.

6 WRITTEN COMMUNICATION(S) FROM MAC - None

7 ADDITIONAL DOCUMENTATION TO SUPPORT EXISTING AGENDA ITEMS

Vice Chair Rotkin referenced his earlier announcements.

CONSENT AGENDA

8-01 RECOMMENDED ACTION ON TORT CLAIMS

8-02 ACCEPT AND FILE PRELIMINARY APPROVED CHECK JOURNAL DETAIL FOR THE MONTH OF MAY 2015

Attachment A

Board of Directors Meeting Minutes
August 14, 2015
Page 3 of 13

- 8-03 ACCEPT AND FILE MINUTES OF THE SANTA CRUZ METRO BOARD OF DIRECTORS MEETING OF JUNE 26, 2015**
- 8-04 ACCEPT AND FILE THE ACCESSIBLE SERVICES REPORTS FOR THE MONTHS OF APRIL, MAY AND JUNE 2015**
- 8-05 ACCEPT AND FILE SANTA CRUZ METRO SYSTEM RIDERSHIP REPORTS FOR THE MONTH OF MAY 2015**
- 8-06 CONSIDERATION OF APPROVAL OF AUDIT ENGAGEMENT LETTER WITH BROWN ARMSTRONG ACCOUNTANCY CORPORATION FOR FINANCIAL AUDIT AND TAX SERVICES FOR THE YEAR ENDED JUNE 30, 2015**
- 8-07 CONSIDERATION OF DECLARING THREE (3) NEW FLYER BUSES AND ONE (1) FLOOR SWEEPER AS EXCESS FOR PURPOSES OF DISPOSAL OR AUCTION**
- 8-08 CONSIDERATION OF REJECTION OF PROPOSAL RECEIVED FROM VISION COMMUNICATIONS CO. AND AWARD OF CONTRACT TO DAY WIRELESS SYSTEMS FOR RADIO SYSTEM MAINTENANCE AND REPAIR NOT TO EXCEED \$177,000**
- 8-09 CONSIDERATION TO ENTER INTO EASEMENT AGREEMENTS WITH THE SCOTTS VALLEY WATER DISTRICT TO INSTALL A STORM WATER FEATURE IMPROVEMENT AT THE CAVALLARO TRANSIT CENTER IN SCOTTS VALLEY**
- 8-10 RATIFICATION OF LICENSE AND INDEMNITY AGREEMENT FOR COMPRESSED NATURAL GAS REFUELING FACILITY USAGE BETWEEN SANTA CRUZ METROPOLITAN TRANSIT DISTRICT (METRO) AND THE SANTA CRUZ TROLLEY CONSORTIUM**
- 8-11 CONSIDERATION OF SECURITY COVERAGE OPTIONS AT PACIFIC STATION**
- 8-12 RECEIVE A FINAL REPORT ON THE CONCEPTUAL REDESIGN OF PACIFIC STATION AND A LIFE OF PROJECT BUDGET**
- 8-13 APPROVE CLASS SPECIFICATION CHANGES TO THE SCHEDULE ANALYST POSITION**
- 8-14 ADOPTION OF THE PARACRUZ SERVICE ELIGIBILITY AND APPEALS PROCESS TO THE SANTA CRUZ METRO ADMINISTRATIVE CODE**

Items 8-08, 8-09 and 8-12 were pulled from the Consent Agenda for discussion and Vice Chair Rotkin renumbered them as Item # 3, 2 and 1, respectively.

ACTION: MOTION TO ACCEPT THE CONSENT AGENDA AS PRESENTED WITH ITEMS 8-08, 8-09 AND 8-12 PULLED FOR DISCUSSION.

MOTION: DIRECTOR LANE

SECOND: DIRECTOR LEOPOLD

DRAFT

8-01A.3

Attachment A

MOTION PASSED UNANIMOUSLY WITH 10 AYES (Directors Bottorff, Bustichi, Chase, Dutra, Friend, Hagen, Lane, Leopold, McPherson and Rotkin) Directors Blitzer and Cervantez were absent.

REGULAR AGENDA

1 (Previously #8-12) RECEIVE A FINAL REPORT ON THE CONCEPTUAL REDESIGN OF PACIFIC STATION AND A LIFE OF PROJECT BUDGET

Referencing the success of the Pacific Station Ad Hoc Committee, Director Dutra proposed that a similar Ad Hoc Committee be established to serve the Watsonville Transit Center (WTC) with the purpose to assist moving forward in the transformation of the WTC. Committee to be comprised of the following: Directors Dutra, Cervantez, Friend and Maria Stead-Rodriguez, a representative from the City of Watsonville, and Erich Friedrich, METRO Sr. Transportation Planner .

Hearing no public comment, the Board moved to make the following motion.

MOTION TO APPROVE THE FORMATION OF THE WATSONVILLE TRANSIT CENTER AD HOC COMMITTEE AND APPROVAL OF THE COMMITTEE MEMBERS AS PROPOSED BY DIRECTOR DUTRA.

MOTION: DIRECTOR DUTRA SECOND: DIRECTOR LANE

MOTION PASSED UNANIMOUSLY WITH 10 AYES (Directors Bottorff, Bustichi, Chase, Dutra, Friend, Hagen, Lane, Leopold, McPherson and Rotkin)

2 (Previously #8-09) CONSIDERATION TO ENTER INTO EASEMENT AGREEMENTS WITH THE SCOTTS VALLEY WATER DISTRICT TO INSTALL A STORM WATER FEATURE IMPROVEMENT AT THE CAVALLARO TRANSIT CENTER IN SCOTTS VALLEY

Chair Bustichi thanked METRO staff and the Scotts Valley Water District (SVWD) for their efforts. Noting that storm water retention is Scotts Valley's number one concern. Ms. Sachi Itagaki, consultant to the SVWD, provided the assembly with a history of the project and brought everyone's attention of page 8-09A.1 for a conceptual design layout where she highlighted various features.

Hearing no public comment, the Board moved to make the following motion.

MOTION TO ENTER INTO THE EASEMENT AGREEMENTS WITH THE SCOTTS VALLEY WATER DISTRICT TO INSTALL A STORM WATER FEATURE IMPROVEMENT AT THE CAVALLARO TRANSIT CENTER IN SCOTTS VALLEY AS PRESENTED

MOTION: DIRECTOR BUSTICHI SECOND: DIRECTOR LEOPOLD

MOTION PASSED UNANIMOUSLY WITH 10 AYES (Directors Bottorff, Bustichi, Chase, Dutra, Friend, Hagen, Lane, Leopold, McPherson and Rotkin) Directors Blitzer and Cervantez were absent.

Attachment A

3 (Previously #8-08) CONSIDERATION OF REJECTION OF PROPOSAL RECEIVED FROM VISION COMMUNICATIONS CO. AND AWARD OF CONTRACT TO DAY WIRELESS SYSTEMS FOR RADIO SYSTEM MAINTENANCE AND REPAIR NOT TO EXCEED \$177,000

Eduardo Montesino, UTU representative, reported that the radio coverage remains spotty in some areas. As a result, many drivers are relying on their personal mobile phones. He is pleased to have a new agreement in place.

Ciro Aguirre, COO, noted that Day Wireless is aware of the issue(s) Mr. Montesino referenced above and is committed to help resolve the matter. They have committed to bringing in engineering staff to review the sites and identify the causes.

Hearing no further comment, the Board moved to make the following motion.

MOTION TO REJECT THE PROPOSAL RECEIVED FROM VISION COMMUNICATIONS CO. AND AWARD OF CONTRACT TO DAY WIRELESS SYSTEMS FOR RADIO SYSTEM MAINTENANCE AND REPAIR NOT TO EXCEED \$177,000 AS PRESENTED

**MOTION: DIRECTOR LANE SECOND: DIRECTOR BUSTICHI
MOTION PASSED UNANIMOUSLY WITH 10 AYES (Directors Bottorff, Bustichi, Chase, Dutra, Friend, Hagen, Lane, Leopold, McPherson and Rotkin) Directors Blitzer and Cervantez were absent.**

9 YEAR TO DATE FINANCIAL REPORT AS OF MAY 31, 2015

Finance Manager Angela Aitken added commentary to the presentation.

Chair Bustichi asked if the information presented reflected overtime. Finance Manager Aitken responded yes, along with savings achieved through vacancies.

Director Leopold asked if there were indications the Metrobase project budget would end "on budget". CEO Clifford responded that the next agenda item is to amend RNL's engineering services but we are still on track to the approved budget (subject, of course, to close out). He also assured the Board that they would be kept apprised.

ACTION: MOTION TO ACCEPT THE YEAR TO DATE FINANCIAL REPORT AS PRESENTED

**MOTION: DIRECTOR LANE SECOND: DIRECTOR LEOPOLD
MOTION PASSED UNANIMOUSLY WITH 10 AYES (Directors Bottorff, Bustichi, Chase, Dutra, Friend, Hagen, Lane, Leopold, McPherson and Rotkin) Directors Blitzer and Cervantez were absent.**

Attachment A

10 CONSIDERATION OF AUTHORIZING THE CEO TO EXECUTE CONTRACT AMENDMENT #7 WITH RNL DESIGN, INC. AND APPROVE REVISING THE LIFE OF PROJECT BUDGET

Andrew Kreck, Project Manager, Hill International, noted this is an incremental request. They anticipate an early fall completion date.

ACTION: MOTION TO AUTHORIZE THE CEO TO EXECUTE CONTRACT AMENDMENT #7 WITH RNL DESIGN, INC. AND APPROVE REVISING THE LIFE OF PROJECT BUDGET AS PRESENTED

MOTION: DIRECTOR BUSTICHI SECOND: DIRECTOR McPHERSON MOTION PASSED UNANIMOUSLY WITH 10 AYES (Directors Bottorff, Bustichi, Chase, Dutra, Friend, Hagen, Lane, Leopold, McPherson and Rotkin) Directors Blitzer and Cervantez were absent.

11 CONSIDERATION OF A FORMAL ADOPTION OF PAY SCHEDULES FOR MANAGEMENT, UTU-FR, UTU-PC, SEIU-SEA, SEIU-PSA AND SEIU-VMU

Angela Aitken, Finance Manager, summarized the request from CalPERS and the pay scales presented. She noted that the pay scales now include 5 and 10 year longevity as requested. (Reference page 11B.1)

In response to Vice Chair Rotkin's question, Ms. Aitken assured him the only downside would be not complying with CalPERS' request. Chair Bustichi noted that this protects METRO's employees.

Hearing no public comment, the Board made the following motion:

ACTION: MOTION TO FORMALLY ADOPT THE PAY SCHEDULES FOR MANAGEMENT, UTU-FR, UTU-PC, SEIU-SEA, SEIU-PSA AND SEIU-VMU AS PRESENTED

MOTION: DIRECTOR LANE SECOND: DIRECTOR LEOPOLD MOTION PASSED UNANIMOUSLY WITH 10 AYES (Directors Bottorff, Bustichi, Chase, Dutra, Friend, Hagen, Lane, Leopold, McPherson and Rotkin) Directors Blitzer and Cervantez were absent.

12 CONSIDERATION OF A FORMAL RATIFICATION OF A LABOR AGREEMENT BETWEEN UNITED TRANSPORTATION UNION LOCAL 23, FIXED ROUTE, FOR THE PERIOD JULY 1, 2015 THROUGH JUNE 30, 2018

Alex Clifford, CEO/General Manager, spoke to agenda items 12 & 13 simultaneously and provided a history of the discussions between management and unions leading to these proposals, emphasizing that this provides significant financial assistance to METRO; resulting in a savings of over \$500,000. He thanked Mr. Montesino and the others for their efforts.

In turn, Mr. Montesino thanked the Board and Director Leopold for their contributions and assistance in growing METRO.

Attachment A

Vice Chair Rotkin added his thanks to the unions and Mr. Montesino for their assistance and improved communication.

Director Leopold noted that the drivers are METRO's "eyes on the street" and thanked the teams for their efforts, crediting the improved communication which produced a deal the drivers could accept.

Director Hagen observed that he has experienced extraordinary care and service from METRO's drivers during his own regular use of the buses,

Director McPherson continually hears praise for our drivers. He thanked the drivers for their assistance in keeping the service rolling. Their efforts will have a huge financial impact.

Hearing no public comment, the Board made the following motion:

**ACTION: MOTION TO FORMALLY RATIFY THE LABOR AGREEMENT BETWEEN UNITED TRANSPORTATION UNION LOCAL 23, FIXED ROUTE, FOR THE PERIOD JULY 1, 2015 THROUGH JUNE 30, 2018 AS PRESENTED
MOTION: DIRECTOR LEOPOLD SECOND: DIRECTOR HAGEN
MOTION PASSED UNANIMOUSLY WITH 10 AYES (Directors Bottorff, Bustichi, Chase, Dutra, Friend, Hagen, Lane, Leopold, McPherson and Rotkin) Directors Blitzer and Cervantez were absent.**

13 CONSIDERATION OF A FORMAL RATIFICATION OF A LABOR AGREEMENT BETWEEN UNITED TRANSPORTATION UNION LOCAL 23, PARACRUZ, FOR THE PERIOD JULY 1, 2015 THROUGH JUNE 30, 2018

See above; this item was discussed simultaneously with Agenda Item 12.

**ACTION: MOTION TO FORMALLY RATIFY THE LABOR AGREEMENT BETWEEN UNITED TRANSPORTATION UNION LOCAL 23, PARACRUZ, FOR THE PERIOD JULY 1, 2015 THROUGH JUNE 30, 2018 AS PRESENTED
MOTION: DIRECTOR DUTRA SECOND: DIRECTOR CHASE
MOTION PASSED UNANIMOUSLY WITH 10 AYES (Directors Bottorff, Bustichi, Chase, Dutra, Friend, Hagen, Lane, Leopold, McPherson and Rotkin) Directors Blitzer and Cervantez were absent.**

14 CONSIDERATION OF AN ADDENDUM TO THE MANAGEMENT COMPENSATION PLAN

Alex Clifford, CEO/General Manager, noted that there is no union contract for the management team; this addendum mirrors the terms set forth in agenda items 12 and 13 above.

Hearing no public comment, the Board responded.

Director Leopold appreciated leadership mirroring the drivers' contributions to fiscal solutions.

Attachment A

Director McPherson asked what the estimated savings for this package were. Ms. Aitken responded the net savings are approximately \$93,000 over three years.

Director Hagen noted this is a real affirmation of the team effort in the organization.

ACTION: MOTION TO ACCEPT THE ADDENDUM THE MANAGEMENT COMPENSATION PLAN AS PRESENTED

MOTION: DIRECTOR LEOPOLD SECOND: DIRECTOR LANE

MOTION PASSED UNANIMOUSLY WITH 10 AYES (Directors Bottorff, Bustichi, Chase, Dutra, Friend, Hagen, Lane, Leopold, McPherson and Rotkin) Directors Blitzer and Cervantez were absent.

15 CONSIDERATION OF A \$5,000 EARLY RETIREMENT INCENTIVE UPON RETIREMENT PRIOR TO DECEMBER 31, 2015

Alex Clifford, CEO/General Manager, explained the staff report and the possible fiscal impact to METRO.

Vice Chair Rotkin noted that not all retirees' positions would be filled so additional savings could be achieved. CEO Clifford added that the management and Unions would discuss any positions not filled and possibly banking those positions as an offset against future decisions.

Director Dutra asked if there is any indication of the number of retirees anticipated and if there is a 'cap' on the number permitted. CEO Clifford responded that although a large number of retirees would be painful, there isn't a cap and we don't anticipate a need at this time. Management and Union representatives both estimate 5-10 retirees taking advantage of the offer.

Mr. Montesino requested that this incentive be retroactive to August 1, 2015. CEO Clifford agreed.

ACTION: MOTION TO APPROVE THE \$5,000 EARLY RETIREMENT INCENTIVE UPON RETIREMENT PRIOR TO DECEMBER 31, 2015 AS PRESENTED WITH AN AMENDED INCENTIVE DATE CHANGE; I.E., FROM AUGUST 1, 2015 THROUGH DECEMBER 31, 2015

MOTION: DIRECTOR LANE SECOND: DIRECTOR LEOPOLD

MOTION PASSED UNANIMOUSLY WITH 10 AYES (Directors Bottorff, Bustichi, Chase, Dutra, Friend, Hagen, Lane, Leopold, McPherson and Rotkin) Directors Blitzer and Cervantez were absent.

16 CONSIDERATION OF AWARD OF CONTRACT TO TRANSPORTATION MANAGEMENT & DESIGN, INC. FOR COMPREHENSIVE OPERATIONAL ANALYSIS NOT TO EXCEED \$99,987

Erich Friedrich, Sr. Transportation Planner, explained the comprehensive operational analysis and what it means to METRO and the community. The goal is to introduce a new service plan in summer of 2016. He introduced the presenters: Kristina Svensk, Project

Attachment A

Manager, and Russell Chisholm, President of TMD. Ms. Svensk provided commentary to the presentation.

Vice Chair Rotkin opened the floor to public comment.

Mr. Montesino requested outreach efforts be extended to the Spanish speaking community. Ms. Svensk responded that translators are available at key events and all literature is printed in both English and Spanish.

Manuel Martinez thanked METRO management for including the Transit Supervisors in this process.

Director Lane expressed concerns about service and revenue reductions to the District. He asked what the end product would be and if the results would be scalable to enable later options.

Mr. Chisholm answered that their recommendations will be reviewed through strategy discussions with the METRO Board and staff to identify scalability. There will be a baseline and scalable elements; it's about re-invention, not cuts. We want to increase ridership and revenue. The critical point is the implementation process.

Director Leopold noted public involvement is critical to acceptance. He asked: How will we drive the public to participate in the process? Will there be surveys at the pop-ups? What kind of meaningful interaction can happen in 10 minutes?

Ms. Svensk outlined their pop-ups which are informal sessions to enable 1:1 dialog. There are no surveys taken at the pop-ups; this is a continual process built for continual input. The pop-ups also act as an advertisement.

Mr. Chisholm added that the pop-ups are the initial communication point. Public participation will be driven through QR scan points and public media such as Facebook and Twitter. South County pop-ups to be oriented to the Spanish speaking population.

Director Leopold cautioned against a city-centric approach, noting that 49% of the County population lives in the unincorporated areas.

Ms. Svensk said one benefit of the pop-ups is the ability to target geographic representation throughout the community; e.g., flea market, first Friday, etc.

Director Hagen recommended the Senior Center in Watsonville as a potential pop-up site.

Mr. Friedrich highlighted some successes at recent pop-ups, such as the Farmers' Market in Watsonville, where valuable pieces of feedback were obtained. METRO is revising our model to smaller, more successful outreach events.

In response to Directors' questions, Ms. Svensk highlighted the flexibility of their outreach tools; there will be advertising onboard buses directing the public to the website with links to other agencies such as SCCRTC and various events.

Carolyn Derwing, speaking as a Schedule Analyst, believes this would be good synergy between METRO's Planning Dept. and TMD, drawing on TMD's expertise to create a good product for the future. She feels positive about the project and its importance for the District.

Attachment A

Vice Chair Rotkin noted he is generally skeptical about consultants but believes this is the correct approach; i.e., including staff, drivers, focusing on outreach. He likes the idea of re-invention.

Director Leopold supports the process to ensure countywide participation through outreach.

As a representative from the County of Santa Cruz, Vice Chair Rotkin volunteered to be the fourth member of the Ad Hoc Committee.

Director Bottorff is typically skeptical when it comes to spending money on consultants but he is confident that the Ad Hoc Committee proposed by Director Dutra will represent Watsonville very well. He stressed the importance of the Board making sound county-wide decisions.

Chair Bustichi reminded the assembly of the past study which provided a “trunk and feeder” option which the Board rejected. It is equally important to reach non-bus users who may vote for a tax measure now or in the future. All tax payers need to know that the system makes financial sense.

ACTION: MOTION TO APPROVE THE AWARD OF CONTRACT TO TRANSPORTATION MANAGEMENT & DESIGN, INC. FOR COMPREHENSIVE OPERATIONAL ANALYSIS NOT TO EXCEED \$99,987 AS PRESENTED AND ESTABLISH AN AD HOC COMMITTEE TO INCLUDE DIRECTORS CHASE, DUTRA, BOTTORFF AND ROTKIN WITH THE OPTION OF ADDING A FIFTH MEMBER

MOTION: DIRECTOR DUTRA SECOND: DIRECTOR HAGEN MOTION PASSED UNANIMOUSLY WITH 10 AYES (Directors Bottorff, Bustichi, Chase, Dutra, Friend, Hagen, Lane, Leopold, McPherson and Rotkin) Directors Blitzer and Cervantez were absent.

17 CONSIDERATION OF ONCE A MONTH BOARD MEETINGS AND REVISIONS TO THE METRO ADVISORY COMMITTEE (MAC) BYLAWS

Alex Clifford, CEO/General Manager, reminded the assembly that this item was in response to Director McPherson’s earlier request. The table on page 17.3 reflects the proposed meeting schedule September through December 2015. In December, the Board will evaluate the effectiveness of the new schedule.

The staff report includes a recommendation to form an Ad Hoc Committee to work with the CEO and District Counsel to review the MAC Bylaws, meeting frequency and adopt a scope of duties/responsibilities. The Committee members have not yet been identified.

Prior to opening the floor to the public, Vice Chair Rotkin reiterated that there is no proposal before the Board at the current time to change MAC meeting frequency but to begin discussions regarding the overall function of MAC.

Will Regan, VMU representative, noted that once a month board meetings were tried previously. At that time, many of the Board members weren’t able to stay the entire length of the longer meeting and information wasn’t brought forward quickly. We’ve already eliminated the July meeting(s) and are now proposing to cut the remaining meetings in half.

Attachment A

The agenda has increased in size and complexity. Personally, he prefers the twice a month meetings.

Vice Chair Rotkin responded that the Board can reverse this decision at any time and presumes that members would keep the second Friday of the month available in the event of a special meeting.

CEO Clifford volunteered to send an email to the Board members with the specific proposed dates, times and locations.

Manny Martinez expressed concern about the busy lives led by board members. There are challenges ahead. METRO tends to lose their audience towards the end of a long board meeting and crucial discussion items are often placed at end of the meeting.

Becky Taylor, MAC representative, noted that there have been completely full agendas at every Board and MAC meeting she's attended. In fact, at recent MAC meetings, the agenda hasn't been discussed fully in the two hours allotted. The reason there is no communication from MAC is due to their meeting cycle which is the 3rd Wednesday of the month.

Eduardo Montesino expressed concerns about one meeting per month, stating we are a rolling city and need the Board's attention.

Director Lane expressed his concerns and suggested maintaining the current schedule of two meetings per month, like the SCCRTC, with the option of cancelling if there are no urgent items. This would ensure that the next meeting wouldn't be overloaded. He also suggested that Board members hold the current meeting dates on their calendars.

Director McPherson expressed concern about staff time and suggested a start time of 8:30A rather than 9:00A. Special meetings can always be called.

Director Hagen, as past president and member of MAC, supports MAC meeting every two months as several meetings were cancelled in 2014 due to lack of quorum.

Chair Bustichi agreed with Director McPherson. This is a trial and can be adjusted. Special meetings can always be added. We are not cutting off public access or creating all day board meeting(s). This is to allow staff to concentrate on other things; the preparation of board packets every two weeks is time consuming; we want to better utilize staff time. He asked that Board members be engaged while they are in the meetings and allocate the appropriate amount of time and attention. Believes each meeting should be broadcast. Recent subcommittees have proven successful and time saving. The MAC Ad Hoc Committee is a good idea and he nominated Director Hagen to head the Committee.

Director Leopold is willing to test the proposed meeting schedule. The Board has to be prepared in the coming year to re-envision our service cuts and possibly be prepared to meet not only in an accessible, public place, but perhaps in the evenings if there are big decisions to be reached (preferably not on a Friday evening).

ACTION: MOTION TO APPROVE THE ONCE A MONTH BOARD MEETINGS AND REVISIONS TO THE METRO ADVISORY COMMITTEE (MAC) BYLAWS AS

Attachment A

PRESENTED WITH AN ADJUSTMENT TO BEGIN THE MEETINGS AT 8:30A AND WORK TOWARDS TELEVISIONING EACH MEETING.

**MOTION: DIRECTOR McPHERSON SECOND: DIRECTOR FRIEND
MOTION PASSED UNANIMOUSLY WITH 10 AYES (Directors Bottorff, Bustichi, Chase, Dutra, Friend, Hagen, Lane, Leopold, McPherson and Rotkin) Directors Blitzer and Cervantez were absent.**

18 PROPOSED BOARD WORKING SESSION

Alex Clifford, CEO/General Manager, outlined the proposed Board working session noting that he is targeting a date in September 2015.

Hearing no public comment, the Board moved to make a motion.

ACTION: MOTION TO APPROVE THE PROPOSED BOARD WORKING SESSION AS PRESENTED

**MOTION: DIRECTOR LANE SECOND: DIRECTOR ROTKIN
MOTION PASSED UNANIMOUSLY WITH 10 AYES (Directors Bottorff, Bustichi, Chase, Dutra, Friend, Hagen, Lane, Leopold, McPherson and Rotkin) Directors Blitzer and Cervantez were absent.**

19 CEO TO GIVE ORAL REPORT

Alex Clifford, CEO/General Manager, introduced Mr. Isaac Holly, METRO's new IT manager. Mr. Holly has been with METRO for 16 years.

Referencing the State and Federal Legislative update handout, CEO Clifford urged Board approval and support via letters, meetings, etc. He noted that METRO buses will be out of compliance if we do not get support on the bus axle weight legislation; we want to grandfather in the buses we have today.

PEPRA will be discussed at a later meeting in greater detail.

Vice Chair Rotkin suggested creating a delegation to visit legislators. CEO Clifford responded that there may be an opportunity in December to visit Washington, DC.

CEO Clifford will provide the Board members with sample support letters to forward to City, County and State representatives.

20 REVIEW OF ITEMS TO BE DISCUSSED IN CLOSED SESSION

Leslyn Syren, District Counsel, announced the following two items to be discussed in Closed Session. She did not anticipate any announcements after the Closed Session.

1. CONFERENCE WITH LABOR NEGOTIATORS
2. CONFERENCE WITH LEGAL COUNSEL – EXISTING LITIGATION
EEOC No. 556-2015-00345

Attachment A

Board of Directors Meeting Minutes
August 14, 2015
Page 13 of 13

21 ANNOUNCEMENT OF NEXT MEETING: FRIDAY, AUGUST 28, 2015 AT 9:00 AM, SCOTTS VALLEY CITY COUNCIL CHAMBERS, 1 CIVIC CENTER DRIVE, SCOTTS VALLEY, CA

Vice Chair Rotkin announced the next meeting logistics.

Director Lane announced that beginning in August 2015, he and Director Chase will be able to attend only one meeting per month due to a new commitment. He will not be present at the August 28, 2015 meeting.

CEO Clifford asked Gina Pye, Executive Assistant, to confirm quorum for the August 28th meeting.

22 ADJOURNMENT

Vice Chair Rotkin adjourned the meeting at 10:45A

23 The Board recessed to Closed Session.

Respectfully submitted,

Gina Pye
Executive Assistant to the CEO

Pursuant to Section 54954.2(a)(1) of the Government Code of the State of California, this agenda was posted at least 72 hours in advance of the scheduled meeting at a public place freely accessible to the public 24 hours a day. The agenda packet and materials related to an item on this Agenda submitted to the Board of Directors after distribution of the agenda packet are available for public inspection in the Santa Cruz METRO Administrative Office (110 Vernon Street, Santa Cruz) during normal business hours. Such documents are also available on the Santa Cruz METRO website at www.scmtd.com subject to staff's ability to post the document before the meeting.

DRAFT

8-01A.13

- THIS PAGE INTENTIONALLY LEFT BLANK -



DATE: August 28, 2015
TO: Board of Directors
FROM: Alex Clifford, CEO
**SUBJECT: ACCEPT AND FILE MINUTES FOR THE METRO ADVISORY
COMMITTEE (MAC) MEETING OF JUNE 17, 2015**

I. RECOMMENDED ACTION

**That the Board of Directors accept and file the minutes for the METRO
Advisory Committee (MAC) meeting of June 17, 2015.**

II. SUMMARY

- Staff is providing minutes from the MAC meeting on June 17, 2015.
- Each month staff will provide the minutes from the previous MAC meeting.

III. DISCUSSION/BACKGROUND

The Board requested that staff include in the Board Packet minutes from previous MAC meetings. Staff is enclosing the minutes from these meetings as a mechanism of complying with this request.

IV. ATTACHMENTS

Attachment A: Approved Minutes for the MAC meeting of
June 17, 2015

Prepared By: Dawn Martin, Administrative Assistant

V. APPROVALS:

Alex Clifford, CEO/General Manager



MINUTES

MAC MEETING OF JUNE 17, 2015

Attachment A



The METRO Advisory Committee (MAC) met on Wednesday, June 17, 2015 in the Pacific Station Conference Room located at 920 Pacific Avenue in Santa Cruz, California.

1 CALL TO ORDER

Chair, Veronica Elsea, called the meeting to order at 6:05 p.m.

ROLL CALL

MEMBERS PRESENT

Veronica Elsea, Chair

Naomi Gunther, Vice-Chair

Joseph Martinez

Donald Peattie

Ernestina Saldana

Becky Taylor

MEMBERS ABSENT

Len Burns

Nicona Keesaw

Michael Pisano

SANTA CRUZ METRO EMPLOYEES AND MEMBERS OF THE PUBLIC WHO VOLUNTARILY INDICATED THEY WERE PRESENT

Ciro Aguirre, METRO

John Daugherty, Self

Maria Granados-Boyce, METRO

2 AGENDA ADDITIONS/DELETION

None

3 ORAL/WRITTEN COMMUNICATION

Ms. Maria Granados-Boyce, Customer Service Supervisor, distributed "Dump the Pump" pins to all committee members and provided an overview of the national event scheduled for Thursday, June 18, 2015 from 9:00 a.m. – 12:00 noon, fostering the idea that people should ride public transportation. The target locations that will provide information are: Target-Watsonville, Whole Foods-Soquel, the Swift Street courtyard where Kelly's Bakery is located and a table at the METRO Pacific Station. Posters were placed on the buses thanking people for riding the bus. The event was advertised via the Sentinel, radio stations, PSAs and community television.

Ms. Granados-Boyce also discussed the upcoming Santa Cruz County Fair scheduled for September 16-20, 2015. Ms. Granados-Boyce asked for MAC's assistance, by writing a letter to the Board, requesting the return of a fixed route bus at the fair. The METRO booth is very popular and has a great deal of information for the public, but the opportunity to have the 35' foot bus to allow the public to see and feel what the bus is all about makes all the difference. Chair Elsea will write a letter to the METRO Board and be shared with MAC to encourage the Fair Board to allow our bus to be part of our booth presentation.

4 ACCEPT & FILE MINUTES FROM THE METRO ADVISORY COMMITTEE MEETING ON MAY 20, 2015

MOTION: ACCEPT & FILE MINUTES FROM THE METRO ADVISORY COMMITTEE MEETING ON MAY 20, 2015

8-02A.1

Attachment A

Minutes – METRO Advisory Committee

June 17, 2015

Page 2 of 4

MOTION: PEATTIE

SECONDED: SALDANA

MOTION: CARRIED - UNANIMOUS

5 COMMUNICATIONS FROM METRO ADVISORY COMMITTEE

Included in the MAC packet was the letter sent to CEO Clifford by Chair Elsea regarding periodic updates from Mr. Erich Friedrich, Senior Transportation Planner.

Chair Elsea spoke with CEO Clifford prior to the meeting and felt that there was really nothing new to report as Mr. Friedrich has been working primarily on the deficit restructuring. CEO Clifford agreed to have Mr. Friedrich attend the MAC meeting once a quarter. Ms. Gunther made reference to several time changes to the summer schedule, and requested that Mr. Friedrich address the route changes and new schedules.

Chair Elsea announced that the website, cruz511.org, is now available. Chair Elsea was a beta tester and stated that the website includes good information including bus and walking directions.

6 UPDATE ON TICKET VENDING MACHINE (TVM)

Ms. Granados-Boyce reported on the progress of the TVM. Maria has met with Chair Elsea and Mr. Burns several times, and the schematics have been approved. The information has been sent to GenFare; they are in production and should be available soon. Ms. Granados-Boyce and Chair Elsea described the arduous task of proofing and preparing the information prior to having the material ready for production.

The visual files have been received by Ms. Granados-Boyce for the firmware, which allows individuals to hear auditorily from the TVM including Spanish, and are ready for testing.

7 PUBLICITY AND RECRUITING NEW MEMBERS

Ms. Granados-Boyce and Ms. Pye have been collaborating on a tri-fold flyer that can be placed on the buses and available as handouts. Committee discussed ideas of how to recruit new MAC members including reaching out to students of UCSC and Cabrillo. Ms. Gunther emphasized that MAC members are bus riders with first-hand knowledge and represent the interest of riders.

Ms. Saldana is scheduled to meet with Associate Chancellor Ashish of UCSC and asked if she could bring the handouts to her meeting. Ms. Granados-Boyce stated she would provide the handouts when they become available.

Committee also discussed the METRO website and ideas or suggestions that, if added, could be helpful in navigating the MAC links. Chair Elsea conveyed that she is hoping Mr. Harlan Glatt will have a website update available sometime this fall.

8 UPDATE ON FORWARD FACING PRIORITY SEATING

COO Ciro Aguirre provided an update regarding the status of the forward facing seating configuration. METRO has contacted several manufacturers to determine alternatives that would reinstate serviceability of the forward facing seats. American Seating provided a sample of a rotating stanchion, but would not confirm a commitment as a fix. New Flyer is the manufacturer of the majority of METRO's buses. They indicate a differentiation between a passive and an active restraint. The difference being, the active restraint is when a person would need to physically hold on to stay in the seat and the passive restraint is one that sits there, does nothing and is similar to a barrier. New Flyer also would not confirm that this is a fix, which leaves us exactly where we were two years ago.

8-02A.2

Attachment A

Minutes – METRO Advisory Committee

June 17, 2015

Page 3 of 4

Committee and COO Aguirre discussed the option of seatbelts. From a legal standpoint, if you require passengers in the forward facing seats to wear a seatbelt, the requirement is valid for all passengers, as you cannot discriminate.

Discussion continued regarding seating, items brought on the bus, potential storage ideas, Q'POD configuration and mobility devices.

COO Aguirre talked about the next series of technology, whether we will continue with compressed natural gas or begin to look at an alternative type of propulsion system. METRO is looking at electric buses and had an opportunity to test a bus manufactured by BYD. The bus left our Maintenance department with an 88% charge, drove to the Summit, made a turnaround, came back down and returned with a 70% charge. These buses are becoming much more effective and we're trying to find funding.

9 ACCEPTED AND FILED – FIXED ROUTE RIDERSHIP REPORT

Received and filed

10 ACCEPTED AND FILED – PARACRUZ ROUTE RIDERSHIP REPORT

Received and filed

Chair Elsea asked the Committee if the reports made sense or did they want a staff person to come and address any concerns. Hearing nothing at this time, Chair Elsea proposed when a Committee member feels that an item needs to be addressed, let either Ms. Martin or Chair Elsea know, otherwise, we will receive and file the reports.

11 MAC AGENDA WITH SUGGESTED INTRODUCTION FROM CHAIR

At the May 20, 2015 MAC meeting, the Committee discussed the best way to communicate to the public that MAC would accommodate the 8:00 p.m. bus departure schedule from the Pacific Station for their monthly meetings. Chair Elsea developed language for discussion.

MOTION: INSERT LANGUAGE WRITTEN BY CHAIR ELSEA, IN THE AGENDA INTRODUCTION, STATING MAC TO MAKE EVERY EFFORT TO CONCLUDE BUSINESS TO ALLOW PARTICIPANTS TO DEPART ON 8:00 P.M. BUSES FROM PACIFIC STATION

MOTION: GUNTHER

SECONDED: TAYLOR

MOTION: CARRIED - UNANIMOUS

12 CHANGING MEETING DATES/FREQUENCY

Chair Elsea started discussion by stating that the Bylaws indicate MAC meets every third Wednesday, and this can only be changed by amending the Bylaws. Chair Elsea and CEO Clifford discussed the possibility of MAC meeting every other month as CEO Clifford's goal is to reduce staff hours. The Bylaws state that MAC meet no less than once a quarter.

The Committee discussed at length the disadvantages of meeting less than once per month. MAC feels that they have a lot of things they are working on and have full agendas to date. Points were brought up to prioritize the agenda to be more mindful of staff's time. METRO is going through crucial changes that require timely advice and having bi-monthly MAC meetings, in the past, did not seem to be successful. Other issues discussed included the Board would meet four times before a MAC

8-02A.3

Attachment A

Minutes – METRO Advisory Committee

June 17, 2015

Page 4 of 4

meeting if MAC changed to bi-monthly meetings; and MAC felt it would be more difficult for the public if the schedule was not on a monthly basis.

MOTION: CHAIR ELSEA TO WRITE LETTER TO CEO CLIFFORD ASKING THAT MAC REMAIN HAVING MONTHLY MEETINGS, USING EXTREME CARE IN PLANNING STAFF TIME AND ATTENDANCE AND PRIORITIZING THE AGENDA

MOTION: SALDANA

SECONDED: GUNTHER

MOTION: CARRIED - UNANIMOUS

13 ACCESSIBLE SERVICE COORDINATOR POSITION AND BUDGET ITEMS

Chair Elsea started the discussion with a brief overview regarding the Accessible Service Coordinator position changing from 40 hours per week to 20 hours per week. Chair Elsea did share that the Board has decided to hold off on a decision and reevaluate at a later date.

Discussion continued regarding the tasks and duties of the Accessible Service Coordinator position.

14 COMMUNICATIONS TO THE SANTA CRUZ METRO CEO

Chair Elsea will send a letter to CEO Clifford requesting that MAC continue having monthly meetings.

15 COMMUNICATIONS TO THE SANTA CRUZ METRO BOARD OF DIRECTORS

Chair Elsea will send a letter to the Board regarding the upcoming Santa Cruz County Fair.

16 ITEMS FOR NEXT MEETING AGENDA

Items to be discussed/for future agendas:

- Update from Mr. Erich Friedrich regarding schedules and other service changes
- Questions about the Accessible Services Coordinator position

17 DISTRIBUTION OF VOUCHERS

Vouchers were distributed

18 ADJOURNMENT

Meeting adjourned at 7:57 p.m.

Respectfully submitted,
Dawn Martin
Administrative Assistant

8-02A.4



DATE: August 28, 2015
TO: Board of Directors
FROM: Carolyn Derwing, Schedule Analyst/Acting Planner
**SUBJECT: ACCEPT AND FILE SANTA CRUZ METRO SYSTEM RIDERSHIP REPORTS
FOR THE MONTH OF JUNE 2015 AND THE END OF FY15**

I. RECOMMENDED ACTION

This report is for informational purposes only. No action is required.

II. SUMMARY

- This report contains Ridership Summaries and Ridership Statistics for Santa Cruz Metropolitan Transit District's (METRO) fixed route bus service for the month of June 2015.
- June was the last month in FY15 so all Year-To-Date totals are for the entire fiscal year and can be used to make comparisons to FY14.
- System-wide ridership was up 1.2% in June 2015 compared to the same month in 2014.
- UCSC Ridership was up 3.7% in June 2015 compared to the same month in 2014.
- Year-to-date ridership totals, and FY15 totals, for local fixed route service are up 3.2% as compared to FY14.
- Year-to-date ridership totals, and FY15 totals, for the Highway 17 Express are up 3.6% as compared to FY14.
- Year-to-date ridership totals, and FY15 totals, for UCSC are up 6.3% as compared to FY14.
- Year-to-date totals, and FY15 totals, for non-UCSC local ridership (ridership figures that do not include Hwy 17 or UCSC ridership) are only up 0.2% as compared to FY14.
- Total system ridership for FY15 was 5,703,998, up 3.2% from FY14.

III. DISCUSSION/BACKGROUND

Ridership reports are prepared monthly in order to keep the Board of Directors apprised of METRO's ridership statistics and ridership trends. The attached Ridership Summaries and Ridership by Route report reflect ridership statistics for METRO's fixed route bus service for the month of June 2015.

Attachment "A" shows system-wide ridership statistics for June 2015 and compares them to June 2014. System-wide, June 2015 ridership was up 1.2% as compared to the same month in 2014. Local fixed route service was up 1.0% as compared to June

2014. Highway 17 Express service was up by 4.3% in June 2015 as compared to June 2014.

This report also compares complete year-to-date totals for FY15 as compared to FY14. By the end of June, overall ridership for FY15 was up 3.1% compared to FY14. Local fixed route was up by 3.1% for FY15 and Highway 17 was up 3.6% for FY15. Most of these increases in year-to-date totals are reflected in UCSC (6.3%) and Hwy 17 ridership (3.6%) with the rest of the local ridership remaining basically flat with only a very slight 0.2% increase for the year.

Attachment “B” shows UCSC ridership statistics for the month of June 2015 and compares them to the same month in 2014. UCSC experienced an overall increase in ridership of 3.7% for the month of June.

This report also compares UCSC complete year-to-date totals for FY15 as compared to FY14. By the end of FY15, UCSC ridership was up 6.3% as compared to the end of FY14. The increase in overall student enrollment at UCSC is strongly reflected in an increase in UCSC ridership. For FY15 UCSC accounted for 46.1% of the total METRO ridership.

Attachment “C” shows weekday, Saturday and Sunday ridership by route for the month of June 2015. Overall, monthly ridership was up 1.2% in June 2015 as compared to the same month in the previous year. The routes with the highest ridership for the month of June were the Route 71, the Route 16 and the Route 35.

The total system ridership for FY15 was 5.7 million and the Route 16 alone accounted for just over 1 million passengers – roughly 18% of the total system ridership. The Route 71 accounted for 13.6% of the total ridership, followed by the Route 19 with 8.2%. The Hwy 17 had the seventh highest ridership of METRO’s routes accounting for 6.6% of the total ridership.

IV. FINANCIAL CONSIDERATIONS/IMPACT

Revenue derived from passenger fares and passes is reflected in the FY15 revenue. While year to date system-wide ridership is up, net passenger fare revenues are down when compared to budget. The adopted FY15 passenger fares budget was based on the FY14 passenger fares budget, plus a 3% increase, because actual year to date revenues were not yet available.

V. ALTERNATIVES CONSIDERED

There are no alternatives to consider.

VI. ATTACHMENTS

- Attachment A:** Monthly Ridership Summary for June 2015
- Attachment B:** Monthly UCSC Ridership Summary for June 2015
- Attachment C:** Monthly Ridership by Route Report for June 2015

Prepared By: Carolyn Derwing, Schedule Analyst/Acting Planner

VII. APPROVALS:

Thomas Hiltner, Acting Planning and
Development Manager



Approved as to fiscal impact:
Angela Aitken, Finance Manager



Alex Clifford, CEO/General Manager



Monthly Ridership Summary

JUNE 01, 2015 - JUNE 30, 2015

Calendar Operating Days

	This Year	Last Year
Weekdays	22	21
Saturdays	4	4
Sundays	4	5

Bikes and Mobility Devices

	This Year	Last Year*
Bikes	16,910	17,239
Mobility Dev.	1,962	2,112

Monthly System Totals

	Monthly Totals		
	This Year	Last Year*	% Change
Local Fixed Route	360,428	356,931	1.0%
AMTRAK/Highway 17 Express	30,010	28,764	4.3%
System Total	390,438	385,695	1.2%

System Daily Averages

	Weekdays			Saturday			Sunday		
	This Year	Last Year*	% Change	This Year	Last Year*	% Change	This Year	Last Year*	% Change
Local Fixed Route	13,692	13,802	-0.8%	7,702	7,629	1.0%	7,099	7,315	-3.0%
AMTRAK/Highway 17 Express	1,097	1,056	3.9%	741	760	-2.5%	727	709	2.5%
System Total	14,789	14,858	-0.5%	8,443	8,389	0.6%	7,826	8,024	-2.5%

Total Ridership YTD % Change

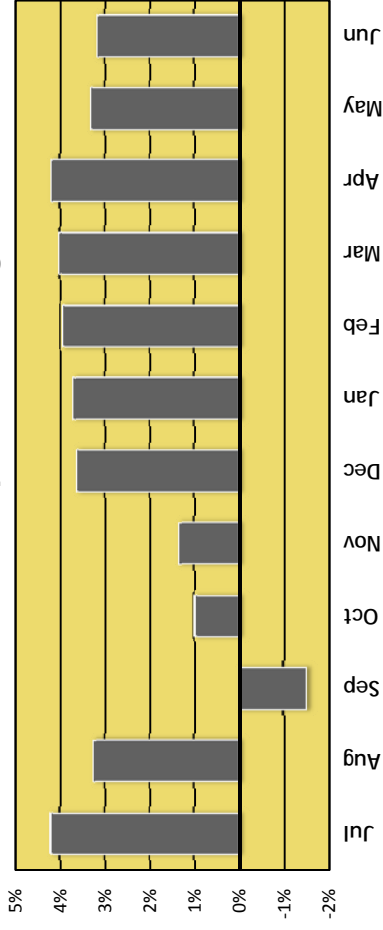

Monthly Ridership - System Totals

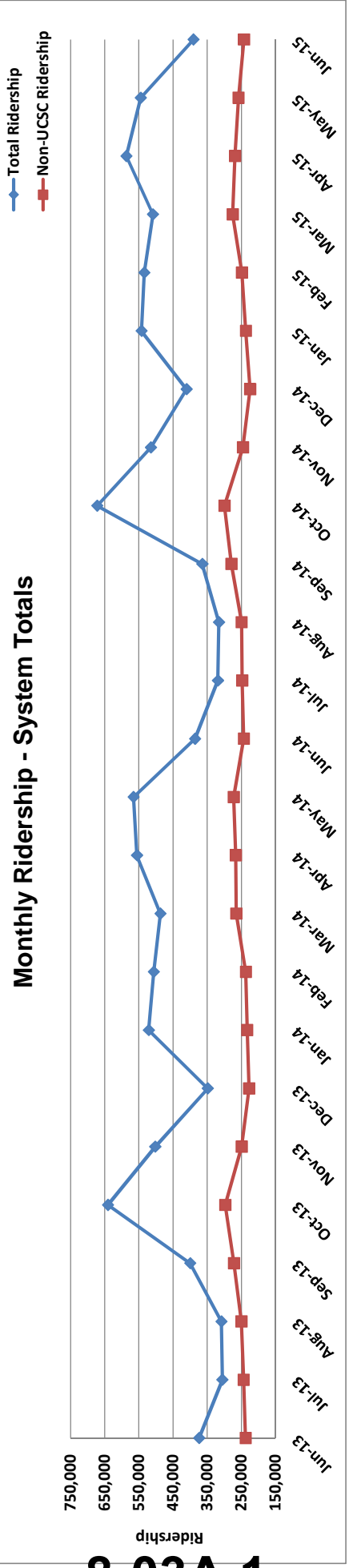

8-03A.1

*Previous year statistics may have been updated since last year's ridership report was produced

- THIS PAGE INTENTIONALLY LEFT BLANK -

UCSC Ridership Summary

JUNE 01, 2015 - JUNE 30, 2015

Calendar Operating Days

	This Year	Last Year	This Year	Last Year	\$ Difference	% Change
School Term Days	9	9	\$184,954.56	\$172,845.98	\$12,108.58	7.0%
Weekdays	22	21	\$16,296.88	\$16,017.56	\$279.32	1.7%
Weekend Days	8	9	\$7,025.12	\$9,202.68	-\$2,177.56	-23.7%
Total			\$208,276.56	\$198,066.22	\$10,210.34	5.2%

UCSC Revenue

UCSC Monthly System Totals

	Monthly Totals			Year to Date Totals		
	This Year	Last Year*	% Change	This Year	Last Year*	% Change
Students	135,996	130,647	4.1%	2,474,300	2,317,614	6.8%
Staff & Faculty	11,983	12,107	-1.0%	152,325	153,869	-1.0%
Total	147,979	142,754	3.7%	2,626,625	2,471,483	6.3%

UCSC System Daily Averages

	School Term Days			Weekdays			Weekend Days		
	This Year	Last Year*	% Change	This Year	Last Year*	% Change	This Year	Last Year*	% Change
Students	9,681	9,135	6.0%	5,329	5,172	3.0%	2,348	2,449	-4.1%
Staff & Faculty	556	537	3.5%	491	509	-3.5%	148	158	-6.2%
Total	10,237	9,672	5.8%	5,820	5,681	2.5%	2,496	2,607	-4.2%

8-03B.1

*Previous year statistics may have been updated since last year's ridership report was produced

- THIS PAGE INTENTIONALLY LEFT BLANK -

Ridership by Route

Attachment C

JUNE 01, 2015 - JUNE 30, 2015

Route	Corridor	Weekday Ridership	Weekday Average	Saturday Ridership	Saturday Average	Sunday Ridership	Sunday Average	Monthly Ridership
3	Mission/Beach	3,455	157	198	50	163	41	3,816
4/4W	Harvey West/Emeline	3,888	177	124	31	88	22	4,100
8	Emeline	126	6					126
10	UCSC via High St.	15,263	694	1,053	263	892	223	17,208
12	UCSC East Side District	527	59					527
15	UCSC via Laurel West	16,915	1,879					16,915
16	UCSC via Laurel East	50,313	2,287	5,014	1,254	4,629	1,157	59,956
19	UCSC via Lower Bay	25,888	1,177	3,014	754	2,387	597	31,289
20	UCSC via West Side	13,343	607	1,732	433	1,745	436	16,820
20D	UCSC via West Side Supp.	6,346	705					6,346
30	Graham Hill/Scotts Valley	589	27					589
33	Lompico SLV/Felton Faire	128	14					128
34	South Felton	35	4					35
35/35A	Santa Cruz/Scotts Valley/SLV	29,090	1,322	3,669	917	3,064	766	35,823
40	Davenport/North Coast	1,339	61	56	14	76	19	1,471
41	Bonny Doon	1,281	58	59	15	32	8	1,372
42	Davenport/Bonny Doon	246	11	38	10	37	9	321
54	Capitola/Aptos/La Selva Beach	128	6	52	13	49	12	229
55	Rio Del Mar	2,485	113					2,485
56	La Selva Beach	412	19					412
66/66N	Live Oak via 17th	11,475	522	1,547	387	1,412	353	14,434
68	Like Oak via Broadway/Portola	7,837	356	945	236	963	241	9,745
69A	Capitola Road/Watsonville	17,115	778	2,375	594	2,061	515	21,551
69W	Cap. Road/Cabrillo/Watsonville	19,889	904	2,715	679	2,413	603	25,017
71	Santa Cruz to Watsonville	47,108	2,141	6,857	1,714	6,941	1,735	60,906
72	Corralitos	3,332	151					3,332
74	Ohlone Parkway/Rolling Hills	1,763	80	168	42	142	36	2,073
75	Green Valley Road	5,088	231	922	231	1,120	280	7,130
77	Civic Plaza / Pajaro	953	43					953
79	East Lake	2,013	92	271	68	180	45	2,464
91X	Santa Cruz/Watsonville Express	12,855	584					12,855
Hwy 17	Hwy 17 Express/AMTRAK	24,139	1,097	2,963	741	2,908	727	30,010
Monthly Total		325,364	14,789	33,772	8,443	31,302	7,826	390,438
Previous Year*		312,022	14,858	33,555	8,389	40,118	8,024	385,695
% Change		4.3%	-0.5%	0.6%	0.6%	-22.0%	-2.5%	1.2%

*Previous year statistics may have been updated since last year's ridership report was produced

- THIS PAGE INTENTIONALLY LEFT BLANK -



DATE: August 28, 2015
TO: Board of Directors
FROM: Thomas Hiltner, Acting Planning and Development Manager
**SUBJECT: ACCEPT AND FILE STATUS REPORT OF ACTIVE GRANTS AND
SUBMITTED GRANT PROPOSALS FOR AUGUST 2015**

I. RECOMMENDED ACTION

That the Board receive and file the monthly status report on grants and applications and change this to a quarterly report to the Board.

II. SUMMARY

- METRO's Final FY16 budget shows approximately 30% of its operating revenue and about 94% of its capital budget derived from grants.
- A list of METRO's active grants (**Attachment A**), grant applications (**Attachment B**) and a grant-funding outlook (**Attachment C**) are provided monthly in order to apprise the Board of the status of grants funding.
- METRO has active grant awards totaling \$44,769,687.
- METRO staff is processing applications totaling \$7,336,460 for new projects.
- No action is required; this report is for information only.
- Going forward, staff will provide this report quarterly.

III. DISCUSSION/BACKGROUND

METRO relies upon grant funding for more than 30% of its FY16 operating revenue and 94% of its FY16 capital funding. The Transportation Development Act (TDA), State Transit Assistance (STA) and the Federal Transit Administration (FTA) annually allocate funds by formula while others, such as the Monterey Bay Unified Air Pollution Control District, the California Energy Commission and Caltrans award discretionary planning grants based upon merit. METRO relies on both formula and discretionary grant revenue to support its operating and capital budgets.

This staff report is to apprise the Board of Directors of active grants funding for current projects, applications for new funds and foreseeable opportunities for future grants. **Attachment A** lists all of METRO's active grants with the award amount, the remaining balance and the status of the projects funded by the grant. **Attachment B** lists METRO's open grant applications with a brief description, source and status of proposed projects. **Attachment C** is a list of future grant opportunities anticipated to arise based upon previous grant-seeking

experience, new programs and pending legislation, which could produce future grant opportunities. In the future, staff will present this report to the Board every quarter rather than monthly.

IV. FINANCIAL CONSIDERATIONS/IMPACT

Active grant awards for operating and capital projects total \$44,769,687, a decrease of \$440,505 due to moving the FY15 Transit Security grant from an Active to an Application since it has not yet been funded.

The unspent balance of active grants is \$27,550,240, a decrease of approximately \$5.4 million from June due to SCCRTC payments on the FY16 TDA operating assistance grant and two months of project progress payments for Pacific Station and MetroBase. Please see **Attachment A**.

Current grant applications request \$7,336,460 an increase of approximately \$2.8 million from June due to adding \$440,505 from the unpaid security grant (above) and the addition of another \$2.7 million in FY15 FTA 5307 Urbanized Area Formula Funds grant in order to claim the full FY15 allocation rather than one-half of it for the first six months of FY15 operations. Please see **Attachment B**.

Attachment C lists funding sources for which METRO can reasonably anticipate future grant solicitations. The current funding environment heavily favors sustainable communities strategies as well as low- and zero-emission buses, especially in areas serving disadvantaged communities. METRO should be prepared to apply for electric bus funding when the opportunities arise.

V. ALTERNATIVES CONSIDERED

This is for information only and there are no alternatives to consider.

VI. ATTACHMENTS

Attachment A:	METRO Active Grants as of August 17, 2015
Attachment B:	METRO Grant Applications as of August 17, 2015
Attachment C:	METRO Future Grant Opportunities as seen on August 17, 2015

VII. APPROVALS:

Thomas Hiltner, Acting Planning
and Development Manager



Approved as to form:
Leslyn K. Syren, District Counsel



Approved as to fiscal impact:
Angela Aitken, Finance Manager



Alex Clifford, CEO/General Manager



- THIS PAGE INTENTIONALLY LEFT BLANK -

Attachment A

Santa Cruz METRO
Active Grants as of August 17, 2015

#	Grant	Description	\$ Grant Awarded	\$ Grant Balance	Local Share	Grant Status
1	FY13 Cal-OES Transit Security Grant Program Expiration: 3/31/16	Comprehensive Security and Surveillance	\$ 440,505	\$ 279,477	-	Funds are being used to complete the LMR project and for fencing and gates at MetroBase \$ Grant Balance as of 8/17/15.
2	FY12 Cal-OES Transit Security Grant Program Expiration: 9/30/15	Comprehensive Security and Surveillance	\$ 440,505	\$ 440,505	-	Requested 1-year extension to complete all projects. \$ Grant Balance as of 8/17/15.
3	FY 11/12 Proposition 1B - State and Local Partnership Program (SLPP) Expiration: 12/11/15	CTC	\$ 5,812,000	\$ 840,903	840,903	Proposition 1B (2006) funds in the SLPP are used exclusively to pay the Lewis C. Nelson contract. LCN has completed interior partitions, exterior wrap, glazing, ADA access ramp, stairs, parking aprons and construction is moving to interior finishing. Grant Balance as of 8/17/15.
4	FY10 - 13 PTMISEA funds (Public Transportation Modernization, Infrastructure and Service Enhancement Act) Expiration: 6/30/17	MetroBase development, Judy K. Souza Operations Facility	\$ 12,010,147	\$ 4,137,824	-	PTMISEA funds through FY13 are for the MetroBase JKS Operations Facility including the temporary operating facility. \$ Grant Balance as of 8/17/15.

Attachment A

Santa Cruz METRO
Active Grants as of August 17, 2015

#	Grant	Description	\$ Grant Awarded	\$ Grant Balance	Local Share	Grant Status
5	FY15 PTMISEA Award/Payment received December 2014 Expiration: 6/30/2020	Funds allocated to Pacific Station subject to Board approval.	\$ 5,949,126	\$ 5,949,126	-	METRO received the second advance payment from Caltrans 4/14/15.
6	Pacific Station Design Engineering FTA 5309 CA-04-0021 Expiration: None	Contract architectural and engineering services for Pacific Station expansion and renovation	\$ 396,000	\$ 114,909	\$ 28,727	Group 4 presented the project status 6/26/15 for BOD consideration and delivered the final Report 8/14/15. Grant Balance as of 8/17/15.
7	Pacific Station Design Engineering FTA 5309 CA-04-0102 Expiration: 9/30/15	Contract architectural and engineering services for Pacific Station expansion and renovation	\$ 490,000	\$ 33,010	\$ 8,253	Group 4 presented the project status 6/26/15 for BOD consideration and delivered the final Report 8/14/15. Grant Balance as of 8/17/15.
8	FY14 FTA 5304 Planning Internship Expiration: 8/31/16	Hire a student intern to gain experience in public transit planning.	\$ 40,281	\$ 24,278	\$ 3,145	Caltrans awarded Internship grant 8/13/13 for \$40,281. Interns are supporting Planning Department staff as directed. \$ Grant Balance as of 8/17/15.

Attachment A

Santa Cruz METRO
Active Grants as of August 17, 2015

#	Grant	Description	\$ Grant Awarded	\$ Grant Balance	Local Share	Grant Status
9	FY14 Caltrans FTA 5304 Planning Grant Expiration: unknown	METRO assistance to RTC Passenger Rail Study	\$ 18,000	\$ 16,270	\$ -	RTC pass-through from Caltrans \$250,000 feasibility study. SCCRTC presented the Final report to the BOD on 6/12/15. \$ Grant Balance as of 8/17/15.
10	2014 Regional Surface Transportation Program (RSTP) Expiration: 6/30/15	Mainline Routes Run-Time Recalibration	\$ 30,000	\$ -	\$ -	Project Completed with final report presented to the Board on 6/26/15. This project will be removed from active Grants. On the next report
11	2014 Surface Transportation Improvement Program (STIP) Expiration: 2/21/18	ParaCruz Van Replacements	\$ 345,000	\$ 251,484	\$ 86,000	Procurement contracted 4 ParaCruz vehicles Two have been delivered with the remaining 2 anticipated by September. \$ Balance as of 8/17/15.
12	FY15 TDA/STA Operating Assistance Expiration: None	FY15 TDA/STA Operating Assistance.	\$ 9,246,726	\$ 531,590	\$ 531,590	RTC paid the FY15 TDA fourth quarter receipts to METRO in June. STA 4th Qtr. Payment is outstanding. \$ Grant Balance as of 6/16/15.
13	FY16 TDA/STA Operating Assistance Expiration: None	FY16 TDA/STA Operating Assistance.	\$ 9,209,643	\$ 9,209,643	\$ 9,209,643	RTC Resolution approved TDA/STA claim on 5/7/15 for operating revenue. \$ Grant Balance as of 8/17/15.

Attachment A

Santa Cruz METRO
Active Grants as of August 17, 2015

#	Grant	Description	\$ Grant Awarded	\$ Grant Balance	Local Share	Grant Status
14	FY14 FTA 5311 Rural Area formula Operating Assistance Award Anticipated: September 2014	Operate Rural Service in Santa Cruz County	\$ 212,267	\$ 177,787	\$ -	METRO submitted an invoice for reimbursement 4/8/15 and is awaiting payment which will complete the project.
15	FY14 Downtown Circulator Planning Study Expiration: 6/30/17	Downtown Circulator Feasibility Study	\$ 74,749	\$ 74,749	\$ 9,684	Grant was awarded 5/28/14 as a Downtown Circulator Study. Staff has re-scoped to aid Comprehensive Operating Assessment. Contract Award anticipated in September. \$ Grant Balance as of 8/17/15.
16	FY15 Caltrans FTA 5304 Planning Grant pass-through to METRO. Expiration: 3/3/17	METRO assistance to RTC User-Oriented Transit Travel Planning Project.	\$ 4,338	\$ 4,338	\$ -	SCCRTC will reimburse METRO staff up to \$4,338 for a maximum 100 staff hours for technical assistance. Project not started. \$ Grant Balance as of 8/17/15.
17	FY15/16 Caltrans FTA 5310 Senior and Disabled Individuals Mobility Program	Purchase One ParaCruz Expansion Van for Elderly/Disabled program beyond ADA requirements.	\$ 50,400	\$ 50,400	\$ 12,600	CTC awarded METRO \$50,400 to purchase one ParaCruz vehicle. Awaiting contract from Caltrans.
		Total	\$ 44,769,687	\$ 22,136,293	\$ 10,730,545	

Attachment B

Santa Cruz METRO
Applications as of August 17, 2015

#	Grant	Description	\$ Grant	Local Share	Funding Source	Status of Award
1	Purchase non-revenue electric vehicle Application due Date: 6/25/16 Awards: 9/16/15	Electric non-revenue vehicles.	\$ 31,678	-	AB2766 - Vehicle registration fees	Applications submitted; Awards to be announced 9/18/15.
2	Purchase electric vehicles charging infrastructure Application : 6/25/16 Awards: 9/16/15	Electric vehicle chargers	\$ 39,871	-	AB2766 - Vehicle registration fees	Applications submitted; Awards to be announced 9/18/15.
3	2014 FTA 5339 Formula Funds Application due 7/3/15 Awards 9/30/15	non-Revenue Vehicles, Repair, Equipment	\$ 916,819	\$ 229,205	FTA FY15 5339 Formula Allocation (assumed)	Application Submitted. Award anticipated 9/30/15.
4	FY15 FTA 5307 Operating Assistance Expiration: 9/30/18 Award 8/31/15	Urbanized Area operating assistance	\$ 5,467,082	\$ 5,467,082	FTA 5307 Urbanized Area Formula Funds	Application is under review at Department of Labor. Due to California PEPRRA legislation, DOL may withhold grant funding.
5	FY15 Cal-OES Transit Security Grant Award Anticipated: October 2014	Comprehensive Security and Surveillance	\$ 440,505	-	FY14 Prop 1B CTSGP funds from Cal-OES	Received Notice of Project Eligibility on 1/27/14. Staff is working with Cal-OES to determine where the money is.
6	FY14 Cal-OES Transit Security Grant Award Anticipated: August 2015	Comprehensive Security and Surveillance	\$ 440,505.00	-	FY14 Prop 1B CTSGP funds from Cal-OES	Received Notice of Project Eligibility June 2015. Staff is working with Cal-OES to determine where the money is.
		Total	\$ 7,336,460	\$ 5,696,287		

- THIS PAGE INTENTIONALLY LEFT BLANK -

Attachment C

Santa Cruz METRO
Future Grant Opportunities August 2015

#	Proposed Project(s)	Funding Source	Grant Request?	Local Share	Supporters/Stakeholders
1	FY16 Operating Assistance Application est. due Date: 6/30/2016	FTA 5307 program	~\$5,000,000	50%	Finance; CEO
2	FY16 Operating Assistance Application est. due Date: 6/30/2016	FTA 5311 program	~\$200,000	50%	Finance; CEO
3	Affordable housing, Pacific Station or Watsonville; Implement Electric Buses Application due Date: 6/3/16	Cap & Trade: Affordable Housing and Sustainable Communities Program; \$150 Million Statewide	\$1,000,000 - \$8,000,000	0%	Watsonville City Council; Santa Cruz Economic Development Department; Chamber of Commerce; Planning, Public Works; Jimmy Dutra; METRO BOD; AMBAG; RTC; County Economic Development
4	FY16 Low Carbon Transit Operations TBD; Implement Electric Buses; Bus Stop Improvements Application est. due Date: 3/1/2016	SB 862 Low Carbon Transit Operations Program, \$25 Million Statewide	\$ 370,000.00	0%	SCCRTC; TAMC; MST; Caltrans; AMBAG; MBUAPCD; CARB
5	Pacific Station construction Pre-Proposal: 3/4/2016 Application est. due Date: 6/5/2016	US DOT TIGER program \$500 Million Nationwide	\$ 25,000,000.00	20%	City of Santa Cruz Planning and Public Works; Downtown Business Association; Greyhound; Pacific Station Tenants; Federal Transit Administration; Chamber of Commerce; METRO passengers
6	Transit Security Projects Application est. due Date: 3/15/2016; 3/15/2017	Proposition 1B California Transit Security Program Fixed Formula to METRO	\$ 881,010.00	0%	Santa Cruz County Public Works; Santa Cruz Police Department;
7	Bus Stop Improvements Application est. due Date: 6/1/2016	Caltrans 2016 Active Transportation Program	\$150,000 - \$300,000	20%	SCCRTC; AMBAG; District 5 Supervisor; CTA

Attachment C

Santa Cruz METRO
Future Grant Opportunities August 2015

#	Proposed Project(s)	Funding Source	Grant Request?	Local Share	Supporters/Stakeholders
8	Bus Stop Improvements [Rural Only] Application est. due Date: 5/1/2016	Caltrans 2016 Active Transportation Program	\$250,000 - \$300,000	46%	SCCRTC; AMBAG; District 5 Supervisor; CTA
9	ParaCruz Vehicles and Equipment Application est. due Date: 12/15/2015	Caltrans 5310 Mobility Improvement Program	\$250,000 - \$300,000	85%	Elderly and Disabled Transportation Advisory Committee; SCCRTC; AMBAG; CTA; City of Santa Cruz Planning and Public Works
10	Electric Buses Application est. due Date: 9/30/2016	California Energy Commission's Alternative and Renewable Fuel and Vehicle Technology Program	\$2,000,000 - \$5,000,000	Unknown	MBUAPCD; AMBAG; SCCRTC; CTA; ResourceConservation District of Santa Cruz County; CARB; Santa Cruz County Public Works; Legislative Coalition
11	Bus on Shoulder Application Due Date: 10/31/2015	2015-2016 Caltrans Sustainable Transportation Planning \$7.5 Million Statewide	\$50,000 - \$500,000	11%	MST; CTA; Santa Cruz Police Department; CHP; City of Santa Cruz Fire Department; DOT/FTA
12	Signal Pre-emption Feasibility Study Application Due Date: 10/31/2015	2015-2016 Caltrans Sustainable Transportation Planning \$7.5 Million Statewide	\$100,000 - \$200,000	11%	MST; CTA; Santa Cruz Police Department; CHP; City of Santa Cruz Fire Department; DOT/FTA
13	Electric Bus Fleet Application est Due Date: 02/28/2016	CARB Heavy-Duty zero-emission Vehicle Incentive Program	~\$100,000 per new electric bus	0%	SCCRTC; AMBAG; Legislative Coalition
14	H17 Electric Bus Fleet Application est Due Date: 04/04/2016	Transit Inter-city Rail Capital Program \$25 - \$50 Million Statewide	\$8,250,000 maximum	0%	Caltrans; MST; TAMC; SCCRTC; CTA; VTA



DATE: August 28, 2015

TO: Board of Directors

FROM: Alex Clifford, CEO

**SUBJECT: ACCEPT AND FILE SANTA CRUZ COUNTY REGIONAL
TRANSPORTATION COMMISSION (SCCRTC) MEETING MINUTES
REFLECTING VOTING RESULTS FROM SANTA CRUZ METRO
APPOINTEES**

I. RECOMMENDED ACTION

That the Board of Directors Accept and File the Minutes for the Santa Cruz County Regional Transportation Commission (SCCRTC).

II. SUMMARY

- Per the action taken by the Board of Directors, staff is providing the minutes from the most recent meeting of the Santa Cruz County Regional Transportation Commission (SCCRTC).
- Each month staff will provide the minutes from the previous SCCRTC meeting.

III. DISCUSSION/BACKGROUND

The Board requested that staff include in the Board Packet information relating to the voting results from the appointees to the SCCRTC. Staff is enclosing the minutes from these meetings as a mechanism of complying with this request.

IV. FINANCIAL CONSIDERATIONS/IMPACT

None.

V. ALTERNATIVES CONSIDERED

None.

VI. ATTACHMENTS

Attachment A: Minutes of the May 7, 2015 Regular SCCRTC Meeting

Attachment B: Minutes of the June 4, 2015 Regular SCCRTC Meeting

Prepared by: Gina Pye, Executive Assistant

VII. APPROVALS:

Alex Clifford, CEO/General Manager

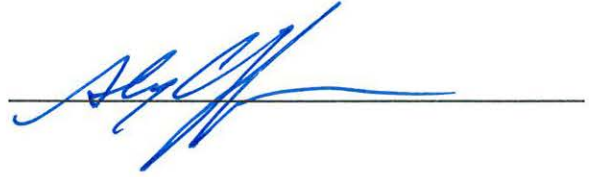

Attachment A



Santa Cruz County Regional Transportation Commission

MINUTES

Thursday, May 7, 2015

**Capitola City Council Chambers
420 Capitola Avenue
Capitola, CA 95010**

1. Roll Call

The meeting was called to order at 9:06 a.m.

Members Present:

Aileen Loe (ex-officio)
Andy Schiffrin (alt.)
Bruce McPherson
Cynthia Chase
Dennis Norton
Don Lane

Ed Bottorff
Greg Caput
Jimmy Dutra
John Leopold
Randy Johnson
Zach Friend

Staff Present:

George Dondero
Luis Mendez
Yesenia Parra
Cory Caletti
Karena Pushnik

Rachel Moriconi
Kim Schultz
Jennifer Rodriguez

2. Oral Communications

Jack Nelson, Campaign for Sensible Transportation, questioned whether there is evidence that highway construction leads to congestion relief.

3. Additions or deletions to consent and regular agendas

Replacement page for Item 12, and additional pages for Items 18, 21, and 22 were distributed.

CONSENT AGENDA

Commissioner Schiffrin moved and Commissioner Lane seconded the consent agenda. The motion passed unanimously, with Commissioners Norton, Lane, Johnson, Dutra, Caput, Friend, Leopold, McPherson, Chase, Bottorff and

8-05A.1

Attachment A

Commissioner Alternate Schiffrin **voting "aye"**. Commissioner Friend and Commissioner Alternate Schiffrin abstained from Item 4.

MINUTES

4. Approved draft minutes of the April 2, 2015 Regional Transportation Commission meeting
5. Accepted draft minutes of the April 13, 2015 Bicycle Committee meeting
6. Accepted draft minutes of the April 14, 2015 Elderly and Disabled Transportation Advisory Committee meeting

POLICY ITEMS

No consent items

PROJECTS and PLANNING ITEMS

7. FY15-16 Transportation Development Act (TDA) Article 8 claims for the Community Traffic Safety Coalition, the Ride 'n' Stride program, and the Bike to work program (**Resolutions 22-15 and 23-15**)

Item pulled by Commissioner Johnson. Chair Leopold placed the item on the regular agenda as item 17.1

8. Received Monterey Bay Region 2015 Public Participation Plan
9. Approved consultant contract for federal transportation/legislative assistant (**Resolution 24-15**)

BUDGET AND EXPENDITURES ITEMS

10. Accepted status report on Transportation Development Act (TDA) revenues

ADMINISTRATION ITEMS

11. Approved appointment of members to the Elderly and Disabled Transportation Advisory Committee

INFORMATION/OTHER ITEMS

12. Accepted monthly meeting schedule
13. Accepted correspondence log
14. Accepted letters from RTC committees and staff to other agencies

Attachment A

- a. Letter to the Honorable William Monning regarding Support for SB 344: Commercial Driver Safety Training
 - b. Letter to the Honorable Jean Fuller regarding Support for SB 516 Transportation: Motorist Aid Services
 - c. Letter to the Honorable Jim Frazier regarding Support for ACA 4, Local Government Transportation Projects: Special Taxes: Voter Approval
 - d. Letter to Caltrans regarding City of Santa Cruz Active Transportation Program Grant Application for Branciforte Creek Pedestrian and Bicycle Bridge from the Elderly and Disabled Transportation Advisory Committee
 - e. Letter to Caltrans regarding City of Scotts Valley Active Transportation Program Grant Application from the Elderly and Disabled Transportation Advisory Committee
15. Accepted miscellaneous written comments from the public on RTC projects and transportation issues
16. Accepted information items
- a. Letter from the Coast Rail Coordinating Council (CRCC)
 - b. Local Groups MAP 21 Renewal letter
 - c. Central Coast Coalition letter
 - d. Grant Confirmation letter from CalTrans

Commissioner Norton pulled item 16a. Chair Leopold placed the item on the regular agenda as item 17.2

REGULAR AGENDA

17. Commissioner reports

Commissioner Norton welcomed all. He shared his vision for the future of transportation stating that 40 feet behind the Capitola chambers, the rail corridor would be built to allow bicycle and pedestrian access and an option for a trolley.

- 17.1 Previously Item 7. In response to questions, Deputy Director Luis Mendez explained the process for putting items on the consent agenda versus the regular agenda, and the invoicing and monitoring process for the projects requesting funding.

Commissioner Johnson moved and Commissioner Alternate Schiffrin seconded to adopt resolutions **(Resolutions 22-15 and 23-15)** approving claims for the FY 2015-16 TDA Article 8 funds for the Community Traffic Safety Coalition, **Ride 'n Stride** and **Bike to Work** programs. The motion passed unanimously, with Commissioners Norton, Lane, Johnson, Dutra, Caput, Friend, Leopold, McPherson, Chase, Bottorff and Commissioner Alternate Schiffrin **voting "aye"**.

- 17.2 Previously Item 16a. Commissioner Norton asked staff to provide an update on the status of the Pajaro train station at a future meeting and directed staff to send a support letter for the Transportation Agency for Monterey County's **Tiger Grant** application.

Attachment A

Commissioner Caput asked for an update on the needed track crossing repairs at Riverside Drive in Watsonville. Executive George Dondero responded that there are discussions with Iowa Pacific, the City of Watsonville and Caltrans currently underway.

18. Director's Report – oral report

Executive Director George Dondero reported the following:

- The RTC was selected as a finalist for a \$5 million Federal Lands Access Program (FLAP) grant award for a rail trail segment west of Santa Cruz. He thanked The Santa Cruz County Land Trust and the Coastal Conservancy for their contribution to the required grant match.
- The RTC received a \$230,000 Caltrans grant for community outreach using computer simulation and 3D software.
- Three agencies will receive Section 5310 grant funding thanks to the work of Transportation Planner Grace Blakeslee on the applications.
- **Governor Brown's new emission target will have an impact on RTC projects and impact other agencies.**
- As part of Bike to Work Week, Ecology Action and Save- our- Shores sponsored a rail line clean up day with RTC staff participation.
- RTC provided funding for the Watsonville Open Streets event that will take place May 17, 2015;
- The RTC would be advertising for a paid intern for the summer

In addition, Mr. Dondero **welcomed the RTC's new Administrative Assistant, Jennifer Rodriguez**

Commissioners congratulated staff on seeking and receiving several grants.

19. Caltrans report and consider action items

Aileen Loe noted the new issue of The Mile Marker Report: Caltrans Performance Report, 3rd edition was released. She noted the short fall in funding for projects under the State Highway Operation and Protection Program (SHOPP). She said the need is about \$8 billion dollars just to preserve the current transportation system. However, the allocation of funds to the SHOPP is only \$2 billion.

Commissioners thanked Caltrans for current safety projects in Ben Lomond; the process for median cleaning; City of Watsonville discussion on roundabouts; and crosswalks by St. Francis High School.

20. **9:30 PUBLIC HEARING** 2015 Unmet Paratransit and Transit Needs

Senior Transportation Planner Karena Pushnik presented the staff report. The RTC regularly solicits input to assess and prioritize the transportation needs of seniors, people with disabilities and low income individuals.

Attachment A

The Public Hearing was opened at 10:03 a.m. There were no public comments. Public hearing was closed at 10:04 a.m.

Commissioners discussed crossings at bus stops and analysis to compare previous years unmet needs.

Commissioner Friend moved and Commissioner Schiffrin seconded to adopt the 2015 Unmet Paratransit and Transit needs report and to consider unmet paratransit and transit needs as funding becomes available. The motion passed unanimously with Commissioners Norton, Lane, Johnson, Dutra, Caput, Friend, Leopold, **McPherson, Chase, Bottorff and Commissioner Alternate Schiffrin voting "aye"**.

21. Bicycle Route Signage Program

Senior Transportation Planner Cory Caletti presented the staff report. Public outreach will be scheduled after phase 1 has been implemented.

Commissioners discussed the fine line between signs that serve as information and visual pollution; sign color requirements; total cost for sign implementation; including parallel routes; number of riders Santa Cruz County serves; changes to the proposed signs and presenting information to the Commission about the proposed grant application.

Eric Child, Santa Cruz pedestrian, said that the report seemed to ignore pedestrian needs and requested that the report make it clear that bicycle paths can and should be shared with pedestrians. He asked that funding be allocated for education so that the rules of the road would be better followed.

Jack Nelson, experienced bike rider, said that good signage would serve both bicycle riders and motorist. He also shared a letter from Amelia Conlen of Bike Santa Cruz County supporting the final report.

Dan Attema, asked if any of the signs would have to be redone once the Monterey Bay Sanctuary Scenic Trail was completed.

Commissioner Friend motioned and Commissioner Alternate Schiffrin second to adopt the Santa Cruz County Bicycle Route Signage program-2015 Implementation Plan. Staff recommendation to adopt a resolution was delayed for the next upcoming RTC meeting.

The motion passed unanimously with Commissioners Norton, Lane, Johnson, Dutra, Caput, Friend, Leopold, McPherson, Chase, Bottorff and Commissioner Alternate **Schiffrin voting "aye"**.

22. Fiscal Year 2015-16 Transportation Development Act (TDA) claims for the Volunteer Center, Community Bridges and Santa Cruz Metro

Senior Transportation Planner Karena Pushnik presented the staff report.

Attachment A

Kirk Ance, Community Bridges, Program Director said Lift Line provides 80 thousands rides per year.

Debbie Brooks, Volunteer Center Transportation Program, said that the program runs on volunteers who use their own vehicles. The service offers door to door rides for the most vulnerable seniors.

Alex Clifford, CEO of Metro, and **Tom Hiltner**, Grants/Legislative Analyst for METRO thanked the RTC for continued support and funding.

Commissioners discussed the effects on riders due to the METRO budget deficit; possible service cuts; sales tax measure to help with budget deficit; labor cost increases, concern for burdening the most vulnerable in the community and appreciation for the service that METRO provides.

Commissioner McPherson moved and Commissioner Friend seconded to adopt resolutions **(Resolutions 24-15, 25-15, 26-15)** to approve the FY 2015-16 Transportation Development Act (TDA) Article 8 funds claim in the amount of \$626,561 from Community Bridges to provide transportation for seniors and people with disabilities, contingent on approval from the City of Santa Cruz to act as the claimant; and approving the FY 2015-16 TDA Article 8 funds claim in the amount of \$74,591 from the Volunteer Center to administer the volunteer driver transportation program primarily serving seniors, contingent on approval from the City of Santa Cruz to acts as the claimant. The motion passed unanimously with Commissioners Norton, Lane, Johnson, Dutra, Caput, Friend, Leopold, McPherson, **Chase, Bottorff and Commissioner Alternate Schiffrin voting "aye"**.

23. Highway 17 Wildlife Crossing Project

Executive Director George Dondero presented the staff report. He noted that Highway 17 traffic will not be disrupted as the tunneling will be done underneath the highway. Caltrans is working on the project initiation document while the Land Trust of Santa Cruz County is committed to raise \$1 million dollars to complete the project.

Commissioner Caput departed the meeting.

Commissioners discussed the importance of making safe passages for wildlife and thanked the Land Trust of Santa Cruz County for their leadership on the project.

Commissioner Lane moved and Commissioner Schiffrin seconded to direct staff to send a letter of support to Caltrans to include the Highway 17 Wildlife Crossing project on the 2016 State Highway Operations and Protection Program (SHOPP) project list.

The motion passed unanimously with Commissioners Norton, Lane, Johnson, Dutra, Friend, Leopold, McPherson, Chase, Bottorff and Commissioner Alternate Schiffrin **voting "aye"**.

Attachment A

24. Federal Legislative Update

Commissioner Johnson departed the meeting.

Executive Director Dondero introduced Chris Giglio of Capital Edge. Mr. Giglio indicated that this is a critical time for transportation in Washington DC. He gave an update on legislation related to transportation and noted that having staff in Washington helps move projects forward.

25. Fiscal Year 2015-16 Overall Work Program

Deputy Director Luis Mendez presented the staff report.

Commissioner Schiffrin moved and Commissioner Lane seconded to approve the FY 2015-16 RTC Work Program and authorize the Executive Director to make revisions in response to comments from Caltrans consistent with the approved RTC budget. The motion passed unanimously with Commissioners Norton, Lane, Dutra, Caput, Friend, Leopold, McPherson, Chase, Bottorff and Commissioner Alternate Schiffrin **voting "aye"**.

26. Review of items to be discussed in closed session

Commissioners adjourned to closed session at 10:45 a.m.

CLOSED SESSION

27. Conference with legal counsel—anticipated litigation. Significant Exposure to Litigation to be considered for one case pursuant to Government Code Section 54956.9 (d)(2).

28. Public Employee Performance Review: Executive Director pursuant to Government Code Section 54957(b)

OPEN SESSION

29. Report on closed session

Commissioners reconvened to open session at 11:30 a.m. and there was no closed session report.

30. Meeting adjourned at 11:35 a.m. Next meetings

The next RTC meeting is scheduled for Thursday, June 4, 2015 at 9:00 a.m. at the Watsonville City Council Chambers, 275 Main Street, Suite 400, Watsonville, CA.

The next Transportation Policy Workshop meeting is scheduled for Thursday, May 21, 2015 at 9:00 a.m. at the RTC Offices, 1523 Pacific Avenue, Santa Cruz, CA.

Attachment A

Respectfully submitted,

Yesenia Parra, Staff

Attendees:

Eric Child	
Tom Hiltner	METRO
Ray Cancino	Community Bridges
Dan Medeiros	Land Trust of Santa Cruz County
Lynn Lauridsen	Health Services Agency
Kirk Ance	Community Bridges/CTSA
Jack Nelson	Campaign for Sensible Transportation
Theresa Rogerson	County of Santa Cruz HSA/CTSC
Selena Garcia	County of Santa Cruz HAS/CTCS
Brian Peoples	
Alex Clifford	METRO
Debbie Brooks	Volunteer Center
Dan Attema	

Attachment B



Santa Cruz County Regional Transportation Commission

Minutes

**Thursday, June 4, 2015
9:00 a.m.**

**Watsonville City Council Chambers
275 Main Street, Suite 400
Watsonville, CA**

1. Roll call

The meeting was called to order at 9:06 a.m.

Members present:

Karina Cervantez	Cynthia Chase
Ed Bottorff	Zach Friend
Don Lane	Jimmy Dutra
Greg Caput	John Leopold
Ryan Coonerty	Aileen Loe (ex-officio)
Dennis Norton	Randy Johnson

Staff Present:

George Dondero	Karena Pushnik
Luis Mendez	Rachel Moriconi
Yesenia Parra	Ginger Dykaar
Jennifer Rodriguez	Cory Caletti

2. Oral communications

Lowell Hurst, Watsonville City Council, thanked Caltrans for fixing roads in Watsonville and mentioned that a tourist was recently amazed that Santa Cruz County has working railroad with economic possibilities due to its connection to the outside world.

William Menchine, said the Monterey Bay Sanctuary Scenic Trail master plan and the Rail Feasibility Study document should be merged as one plan.

3. Additions or deletions to consent and regular agendas

A replacement page for Item 10 and two handouts for Item 16 were distributed.

Attachment B

SCCRTC Meeting Minutes

June 4, 2015

CONSENT AGENDA

Commissioner Lane moved and Commissioner Coonerty seconded the consent agenda. The motion passed unanimously with Commissioners Cervantez, Johnson, Lane, Coonerty, Chase, Dutra, Leopold, Bottorff, Caput, Friend, and Norton voting "aye".

MINUTES

4. Approved draft minutes of the May 7, 2015 Regional Transportation Commission meeting
5. Approved draft minutes of the May 21, 2015 Transportation Policy Workshop meeting

POLICY ITEMS

No consent items

PROJECTS and PLANNING ITEMS

6. Received information on the Unified Corridors Investment Study – Phase 1 Update

BUDGET AND EXPENDITURES ITEMS

7. Accepted status report on Transportation Development Act (TDA) revenues
8. Approved amendments to the Fiscal Year 2014-15 Budget and Work Program
(Resolution 29-15)

ADMINISTRATION ITEMS

9. Approved Executive Director's Employment Agreement

INFORMATION/OTHER ITEMS

10. Accepted monthly meeting schedule
11. Accepted correspondence log
12. Accepted letters from RTC committees and staff to other agencies
 - a. Letter to Caltrans regarding City of Santa Cruz Active Transportation Program Grant Application for Branciforte Creek Pedestrian/Bicycle Bridge from the RTC Bicycle Advisory Committee
 - b. Letter to Caltrans regarding City of Watsonville Active Transportation Program Grant Application for Rail Trail Walker Street Project from the RTC Bicycle Advisory Committee

Attachment B

SCCRTC Meeting Minutes

June 4, 2015

- c. Letter to Caltrans regarding RTC Active Transportation Program Grant Application for Santa Cruz County Bicycle Route Signage Program from the RTC Bicycle Advisory Committee

13. Accepted miscellaneous written comments from the public on RTC projects and transportation issues

14. Accept information items

None

REGULAR AGENDA

15. Commissioner reports – oral reports

None

16. Director's Report – oral report

George Dondero, Executive Director, reported that the Cruz511 website is now live and a demonstration would be given at an RTC meeting in the fall. The Monterey Bay Scenic Sanctuary Trail (MBSST) Planning Award from the American Trails Organization was passed around for the Commissioners to view. Mr. Dondero noted that Jeff Weeks, General Manager for Iowa Pacific, accepted a position with Caltrain and thanked Mr. Weeks for his work with the RTC. He also said that Brett Wallace is now the General Manager and the RTC contact. Mr. Dondero also reported that President Obama signed a two-month federal transportation funding extension; and noted some RTC projects that align with National Safety Month.

17. Caltrans report and consider action items

Aileen Loe stated that in 2014 Caltrans reduced their water consumption by 32% and that Caltrans is working to develop a Class 4 bike ways plan that includes guidelines.

18. Appreciation for completed murals on Santa Cruz Branch Rail Line

Luis Mendez, Deputy Director, thanked Arturo Tomei, Steven Allen, John Ton and Mya Negre for their mural work along the Santa Cruz and Monterey Bay rail line in Capitola and Aptos. Mr. Mendez noted that murals deter graffiti, which is a big concern along the rail line property.

Commissioners extended their appreciation of the murals and the significance of the depicted images, and commended the commission and community members for beautifying the community. Commissioner Norton said that the City of Capitola is interested in extending the Capitola mural onto the railroad bridge.

Attachment B

SCCRTC Meeting Minutes

June 4, 2015

Commissioner Friend presented certificates to Arturo Tomei and Steven Allen for the Aptos mural. Commissioner Norton presented certificates to John Ton and Mya Negre for the Capitola mural.

John Ton, Capitola mural artist, stated that murals are a great deterrent to graffiti. He also presented proposed images for the railroad bridge in Capitola.

Chair Leopold called for a break at 9:47 a.m.

The commission reconvened at 10:03 a.m.

19. Draft Passenger Rail Feasibility Study

George Dondero, Executive Director, presented the staff report. He said that the final document will be available in the fall after all public comments are compiled.

Mr. Dondero introduced consultant team members Bob Grandy, Steve, Crosley and Buzz Burger. The consultant team gave a PowerPoint presentation summarizing the feasibility study findings, highlighting the status of the study, and describing and clarifying options from an engineering stand point.

Commissioner Cervantez left the meeting.

Commissioners discussed: the feasibility study estimated costs, ridership forecasts, hybrid studies, agency comparisons, quiet zones, safety, environmental impact cost, capital cost, Federal Rail Administration compliance, options of building in phases, impacts of alternative technologies, community outreach, fare options, funding and the importance of including service to the City of Watsonville.

Bud Colligan, Santa Cruz resident, stated his concerns on: costs for rail operations, climate change, CO2 emissions, the viability of commuter options on the bike path proposed, and the Monterey Bay Sanctuary Scenic Trail (MBSST) master plan. He asked that RTC staff explore issues and understand economic, environmental, and commute benefits of a trail only option; and understand viability vs. feasibility and that the RTC consider rail banking.

Heather Adamson, Association of Monterey Bay Area Government (AMBAG) staff, clarified that the demand model is a 3 county model, which is updated every 5 years.

Cliff Walters, Roaring Camp, communicated that Roaring Camp would like to continue services to the Boardwalk, and noted that some expenses in the plan may not be quite as stated.

Paul Elerick, Campaign for Sensible Transportation, supports rail service and a sales tax measure.

Attachment B

SCCRTC Meeting Minutes

June 4, 2015

Brian Peoples, Aptos Rail Trail, said he's not sure if the plan is feasible, and is concerned about the speed of the train going through communities.

Rick Longinotti, wants the feasibility study to include electrification on the rail line because it's quieter and reduces pollution. He said the diesel trains are dependent on fuel sources that will rise in price.

Eli Puglizevich, Seacliff resident, is concerned with the noise level when the trains honk at rail crossings.

Steve Hill, Vice President of Engineering for Iowa Pacific, stated that Iowa Pacific could provide more reasonable and cost effective service as stated in Scenario S. He also noted that they are very interested in continued efforts in the development of freight service.

Nancy Bilicich, Mayor of Watsonville, supports Scenario G and said that the City of Watsonville needs to be included from the start of the project in order for the city to give its support. The roads in Watsonville need repair and there is a need for funding and alternative transportation.

Lowell Hurst, Watsonville City Council, said that while there are many unknowns, the RTC should be brave and think big.

Barry Scott, Rio del Mar resident, said the RTC needs to keep in mind that the rail corridor is a piece of a bigger transportation system that could link with other transportation corridors and should keep in mind the costs of not having this rail corridor. He also noted that rail banking is not a secure option.

Trina Coffman-Gomez, Watsonville City Council, stated that rail transportation alternatives to Watsonville will provide relief on highways and supports the project but it must include Watsonville.

Ronald Caplan, Seascape resident, said his commute to Scotts Valley via Soquel Avenue is comparable to a Highway 1 commute. The rail option is needed and will help connect to other transportation options. The cost is also 15% less than widening Highway 1.

Commissioners directed RTC staff to extend the comment period until July 31st, 2015. Karena Pushnick, Senior Transportation Planner invited all to the Rail Study Open House being held this evening starting at 6:30 pm at the Simpkins Swim Center in Live Oak.

20. The meeting adjourned to a special meeting of the Service Authority for Freeway Emergencies at 12:21 p.m.

8-05B.5

Attachment B

SCCRTC Meeting Minutes

June 4, 2015

Next meetings

The next RTC meeting is scheduled for Thursday, August 6, 2015 at 9:00 a.m. at the Scotts Valley City Council Chambers, 1 Civic Center Drive, Scotts Valley, CA.

A special meeting of the Transportation Policy Workshop is scheduled for Thursday, June 25, 2015 at 9:00 a.m. at the City of Santa Cruz Council Chambers, 809 Center Street, Santa Cruz, CA.

Respectfully submitted,

Yesenia Parra, Staff

Attendees:

Heather Adamson	Association of Monterey Bay Area Government
Lowell Hurst	City of Watsonville
Trina Coffman-Gomez	City of Watsonville
Dr. Nancy A. Billich	City of Watsonville
Murray Fontes	City of Watsonville
Angela Aitken	Santa Cruz Metro
Kimberly Ferm	Pajaro Valley Shelter Services
Paul Elerick	Campaign for Sensible Transportation
Donald Miller	Valley Heights resident
Cliff Waters	Roaring Camp Railroads
Barry Scott	Rio del Mar resident
Eli Puglitech	Seacliff resident
Ursula Puglitech	Seacliff resident
Buzz Burger	Fehr & Peers
Steve Crosley	Fehr & Peers
Bob Grandy	Fehr & Peers
Brian Peoples	Aptos resident
Steve Hill	Iowa Pacific
Ronald Caplan	Seascape resident
Bud Colligan	Santa Cruz resident
John Ton	
Mya Negre	
Arturo Tomei	
Steven Allen	
Brandon Kett	
Eric Child	
Trevor Park	
William Menchine	
Rick Longinotti	



DATE: August 28, 2015
TO: Board of Directors
FROM: Andrew Kreck, Project Manager, Hill International
SUBJECT: CONSIDERATION OF METROBASE MONTHLY CHANGE REPORT

I. RECOMMENDED ACTION

That the Board of Directors accept and file the MetroBase Monthly Change Report.

II. DISCUSSION/BACKGROUND

The Santa Cruz Metropolitan Transit District (METRO) has a contract with Lewis C. Nelson and Sons, Inc. for the construction of the Judy K. Souza Operations Building.

Per the Board’s request, the Project Manager is to provide a monthly summary of change orders. Since the Report to the Board on June 26, 2015, the following Change Orders have been executed.

Change Order Number	Description	Increase in Contract Time (Days)	Increase in Contract Amount
019	CalTrans Encroachment Permit	Deferred Time	\$23,523.00
039 Supplemental 1	Buy America FRC Panels	Deferred Time	\$0
047	Concrete Backfill at Waterline in River Street	Deferred Time	\$28,444.00
048	Boulder Removal	Deferred Time	\$632.00
053	Delete Grout Bed	Deferred Time	-\$2,382.00
054	Edge of Slab Revision	Deferred Time	\$1,297.00
062	Chain Link Fence on Retaining Wall	Deferred Time	\$2,234.00

Total **\$53,748.00**

III. FINANCIAL CONSIDERATIONS/IMPACT

See attached.

IV. ATTACHMENTS

Attachment A: Executed Change Orders Table

Prepared by: Joan Jeffries, Administrative Assistant
Jaron West, Hill International, Inc.

V. APPROVALS:

Andrew Kreck, Project Manager



Approved as to form:
Leslyn K. Syren, District Counsel



Approved as to fiscal impact:
Angela Aitken, Finance Manager

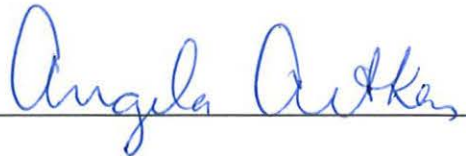

Alex Clifford, CEO/General Manager



- THIS PAGE INTENTIONALLY LEFT BLANK -

Attachment A

Executed Change Orders

Contract No. 12-23

Original Contract Amount:	\$13,572,000.00	Revised Contract Amount:	\$14,440,916.18
Original Contract Time (Days):	668	Revised Contract Time (Days):	779
Total Project Contingency:	\$1,832,365.00	Contingency Remaining:	\$1,731,605.00

No.	Effective Date	Description	Increase in Contract Amount	Increase in Contract Time (in Days)	Approved By
001	5/16/13	Site improvements at 135 Dubois	\$ 200,586.00	-0-	Board/Les White
002	6/4/13	Extend completion date by 49 days	\$ -	49	Board/Les White
003	6/4/13	Additional site improvements at 135 Dubois	\$ 36,369.00	-0-	Les White
004	6/4/13	Demolish concrete sound wall; Provide Pile Driving Notification	\$ 17,297.00	-0-	Les White
005	6/4/13	Demolish CPU planter wall, trees, shrubs, and chain link fencing	\$ 8,905.00	-0-	Les White
006	7/25/13	Expose tops of overdriven piles	\$ 2,324.00	-0-	Les White
007	8/7/13	Cut off prestressed concrete piles 54 ft. long or less	\$ 50,000.00	-0-	Les White
007 S1	4/21/15	Cut off prestressed concrete piles 54 ft. long or less	\$ -	16	Board/Alex Clifford
008	9/26/13	Cut off prestressed concrete piles longer than 54 ft. to achieve correct elevation	\$ 26,000.00	-0-	Les White
009	9/26/13	Provide labor, equipment, and materials to modify pile caps	\$ 18,994.00	-0-	Les White
010	9/15/14	Fire Service Backflow Preventor (FD #17)	\$ 10,621.00	-0-	Alex Clifford
011	2/25/14	Weather & Misc. Delay	\$ -	13	Board/Alex Clifford
012	11/20/14	Differing site condition encountered during parking lot demolition.	\$ 49,777.00	-0-	Alex Clifford
013	11/20/14	Modification of parking deck storm drain piping at grid lines E/1 on ground floor	\$ 1,920.00	-0-	Alex Clifford
014	3/17/15	Add battery backups/delete overhead coils	\$ -	-0-	Alex Clifford
015	12/8/14	Partnering sessions (METRO's one half share of cost)	\$ 10,000.00	-0-	Alex Clifford
016	1/6/15	Furnishing and installing of epoxy-coated rebar dowels	\$ 3,798.68	-0-	Alex Clifford
017	1/14/15	Additional vehicular PCC pavement	\$ 15,182.00	-0-	Alex Clifford

Attachment A

No.	Effective Date	Description	Increase in Contract Amount	Increase in Contract Time (in Days)	Approved By
018	6/16/15	Aluminum Brake Metal	\$ 28,280.50	Deferred	Alex Clifford
019	6/26/15	CalTrans Encroachment Permit	\$ 23,523.00	Deferred	Alex Clifford
020	6/16/15	Relocate Firewall - Door Louvers and FSDs	\$ (803.00)	Deferred	Alex Clifford
022	6/16/15	Elevator Penthouse	\$ 23,870.00	Deferred	Alex Clifford
023	5/4/15	Stair Gate	\$ 4,446.00	-0-	Alex Clifford
025	6/16/15	Illuminated Handrail	\$ 21,668.00	Deferred	Alex Clifford
026	6/16/15	Plumbing Changes	\$ 6,740.00	Deferred	Alex Clifford
027	6/8/15	Security Camera Conduits	\$ 55,616.00	Deferred	Alex Clifford
028	6/8/15	Future Car Charging Conduits	\$ 21,399.00	Deferred	Alex Clifford
029	6/16/15	Contaminated Soil Abatement	\$ 32,011.00	Deferred	Alex Clifford
030	6/16/15	HVAC Revisions - Split System	\$ 14,385.00	Deferred	Alex Clifford
031	3/17/15	Pile Redesign	\$ 62,942.00	12	Board/Alex Clifford
032	3/17/15	Pile Cap Redesign	\$ 31,717.00	21	Board/Alex Clifford
033	3/17/15	Additional Sitework	\$ 12,799.00	-0-	Alex Clifford
035	6/16/15	Provide Cut Metal Letters	\$ 19,467.00	Deferred	Alex Clifford
036	4/8/15	Dwarf Wall & 6 Inch Sill Curb	\$ 6,712.00	-0-	Alex Clifford
039.S1	7/10/15	Buy America FRC Panels	\$ -	Deferred	Alex Clifford
040	6/16/15	Added Motor Operated Solar Shades	\$ 20,199.00	Deferred	Alex Clifford
043	6/16/15	PG&E Gas and Electric Substructures	\$ 2,499.00	Deferred	Alex Clifford
047	7/7/15	Concrete Backfill at Waterline in River Street	\$ 28,444.00	Deferred	Alex Clifford
048	6/25/15	Boulder Removal	\$ 632.00	Deferred	Alex Clifford
051	6/16/15	Delete Fixture Type DD at Transformer Enc.	\$ (905.00)	Deferred	Alex Clifford
052	6/16/15	Relocate Fixture Type WE	\$ 352.00	Deferred	Alex Clifford
053	7/6/15	Delete Grout Bed	\$ (2,382.00)	Deferred	Alex Clifford
054	7/10/15	Edge of Slab Revision	\$ 1,297.00	Deferred	Alex Clifford
062	7/30/15	Chain Link Fence on Retaining Wall	\$ 2,234.00	Deferred	Alex Clifford

Totals: \$ 868,916.18 111



DATE: August 28, 2015
TO: Board of Directors
FROM: Angela Aitken, Finance Manager
**SUBJECT: RENEWAL OF PROPERTY INSURANCE COVERAGE FOR FY16
WITH ZURICH AMERICAN INSURANCE COMPANY**

I. RECOMMENDED ACTION

That the Board of Directors authorizes renewal of property insurance coverage with Zurich American Insurance Company.

II. SUMMARY

- Santa Cruz METRO maintains property insurance on all its owned facilities and on leased facilities in accordance with lease agreements, as well as on building contents.
- Staff recommends that the Board of Directors authorize the renewal of property insurance coverage with Zurich American Insurance Company in the amount of \$50,018.

III. DISCUSSION/BACKGROUND

Barney & Barney, Santa Cruz METRO's property insurance broker, has arranged for renewal of property insurance coverage with Zurich American Insurance Company. This is all risk coverage, excluding earthquake and flood, and includes buildings and contents, computer and telephone systems, employee tools, and other equipment, with a \$5,000 deductible.

The Zurich American Insurance Company is rated A+ XV by A. M. Best. The "A+" is the superior or highest rating on the A.M. Best rating scale, and "XV" refers to financial size category (FSC) and is based on adjusted policyholders' surplus. "XV" translates to two billion or greater.

Santa Cruz METRO does not carry earthquake insurance.

Santa Cruz METRO carries flood insurance under a separate policy for the Fueling and Service Building at 1200 "B" River Street. The flood insurance for the former Operations Building at 1200 River Street was cancelled due to construction of the Judy K. Souza Operations Facility and Santa Cruz Metro will need to add coverage prior to assuming occupancy.

Staff recommends that the Board of Directors authorize the renewal of property insurance coverage with Zurich American Insurance Company in the amount of \$50,018. The year over year decrease is \$14 or 0%.

IV. FINANCIAL CONSIDERATIONS/IMPACT

The following outlines the elements of the above recommendation:

1. **AMOUNT OF RECOMMENDATION:** \$50,018
2. **SOURCE OF FUNDING:** FY16 Operating Budget
3. **EXPENSE ACCOUNTS TO CHARGE:** Ins. Property - 506011
4. **FISCAL IMPACT:**
 - The cost for the recommendation of renewal of property insurance in the amount of \$50,018 is included in the Finance Department FY16 - FY17 final operating budget.

V. ALTERNATIVES CONSIDERED

- Using an alternate insurance carrier is certainly an option but could negatively impact the cost.
 - Switching carriers to Zurich American Insurance two years ago and consolidating all properties to a single policy rather than two, contributed to a significant reduction in our annual premium.
- The Judy K. Souza Operations Facility is currently covered by a “builder’s risk” policy with Zurich American Insurance Company paid by Lewis C. Nelson & Sons, Inc. through December 18, 2015, as a requirement of their contract.
- Santa Cruz METRO could self-insure – but the agency does not currently have the cash reserves to support such a program.

VI. ATTACHMENTS

None

Prepared By: Debbie Kinslow, Assistant Finance Manager

VII. APPROVALS:

Angela Aitken, Finance Manager



Approved as to form:
Leslyn K. Syren, District Counsel



Approved as to fiscal impact:
Angela Aitken, Finance Manager

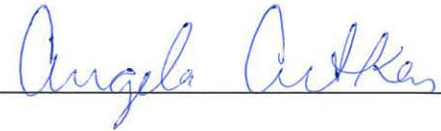

Alex Clifford, CEO/General Manager



- THIS PAGE INTENTIONALLY LEFT BLANK -



DATE: August 28, 2015
TO: Board of Directors
FROM: Al Pierce, Maintenance Manager
SUBJECT: CONSIDERATION OF AUTHORIZING THE CEO TO EXECUTE A CONTRACT EXTENSION WITH AIRTEC SERVICE FOR HVAC MAINTENANCE SERVICES, INCREASING THE CONTRACT TOTAL BY \$22,000

I. RECOMMENDED ACTION

That the Board of Directors authorize the CEO to execute a contract extension exercising the 4th and final option with Airtec Service for HVAC Maintenance Services, increasing the contract total by \$22,000 for the additional one-year period, for a new contract not-to-exceed of \$118,000.

II. SUMMARY

- The Santa Cruz Metropolitan Transit District (METRO) has a contract with Airtec Service for HVAC Maintenance Services that will expire on October 13, 2015.
- Airtec Service has requested a 2.4% price increase for the new contract period. The contract allows for this price increase.
- Airtec Service has performed its duties very well under this contract, and therefore a one-year contract extension with a 2.4% price increase for the new contract period is recommended.

III. DISCUSSION/BACKGROUND

METRO has a contract with Airtec Service for heating, ventilation, and air conditioning (HVAC) maintenance services that was established on October 14, 2011 for a one-year period, with four optional one-year extensions. The current contract is due to expire on October 13, 2015. Per Al Pierce, Maintenance Manager, over the past year the quality of service provided by Airtec Service has been good. Airtec Service has reviewed the contract and requested a 2.4% price increase for the new contract period. The contract allows for this price increase.

Staff recommends that METRO exercise the 4th and final option for a one-year contract extension with Airtec Service for an amount not to exceed \$22,000. Staff further recommends that the Board of Directors authorize the CEO to sign a one-year contract extension on behalf of METRO. Al Pierce, Maintenance Manager, will continue to serve as the Contract Administrator and will ensure contract compliance.

IV. FINANCIAL CONSIDERATIONS/IMPACT

This contract has a total not to exceed of \$96,000. Additional funds in an amount of \$22,000 are requested for approval at this time. The new contract total not to exceed would be \$118,000.

Funds to support this contract are included in the Facilities Maintenance FY16 & FY17 Out Repair - Buildings & Improvements (503351) Operating Budgets.

V. ALTERNATIVES CONSIDERED

- Do not renew this contract. Staff does not recommend this option, as METRO does not have in-house staff trained or certified to perform these mechanical maintenance services.

VI. ATTACHMENTS

Attachment A: Renewal letter from Airtec Service

Attachment B: Sixth Amendment to the Contract with Airtec Service

Prepared By: Joan Jeffries, Administrative Assistant
Al Pierce, Maintenance Manager

VII. APPROVALS:

Al Pierce, Maintenance Manager



Approved as to form:
Leslyn K. Syren, District Counsel



Approved as to fiscal impact:
Angela Aitken, Finance Manager



Alex Clifford, CEO/General Manager



- THIS PAGE INTENTIONALLY LEFT BLANK -

Attachment A



July 7, 2015

Santa Cruz Metro
110 Vernon Street
Santa Cruz, CA 95060

Attn: Erron Alvey

Re: Intent to Extend HVAC Maintenance Services
Contract Number 12-09

Erron,

Airtec Service wishes to extend the maintenance agreement contract through October 13, 2016. However, we would like to request a cost of living increase of 2.4%.

Please advise if this is acceptable.

Sincerely,

A handwritten signature in blue ink, appearing to read "David Olson", is written over a large, stylized blue oval scribble.

David Olson
President

- THIS PAGE INTENTIONALLY LEFT BLANK -

Attachment B

SANTA CRUZ METROPOLITAN TRANSIT DISTRICT SIXTH AMENDMENT TO CONTRACT NO. 12-09 FOR HVAC MAINTENANCE SERVICES

This Sixth Amendment to Contract No. 12-09 for HVAC Maintenance Services is made effective October 14, 2015 between the Santa Cruz Metropolitan Transit District (“Santa Cruz METRO”), a political subdivision of the State of California, and Airtec Service (“Contractor”).

I. RECITALS

- 1.1 Santa Cruz METRO and Contractor entered into a Contract for HVAC Maintenance Services (“Contract”) on October 14, 2011.
- 1.2 The Contract allows for amendment upon mutual written consent.
- 1.3 Santa Cruz METRO and Contractor desire to amend the Contract to extend the Contract term and to increase the Contract total not-to-exceed amount.

Therefore, Santa Cruz METRO and Contractor amend the Contract as follows:

II. TERM

- 2.1 Article 4.01 is replaced in its entirety by the following:

The term of this Contract shall be from October 14, 2011 to October 13, 2016.

Santa Cruz METRO and Contractor may extend the term of this Contract at any time for any reason upon mutual written consent.

III. COMPENSATION

- 3.1 Article 5.01 is amended to include the following language:

A price increase of 2.4% shall be effective on October 14, 2015. Santa Cruz METRO shall compensate Contractor in an amount not to exceed the rates agreed upon and set forth in Contractor’s proposal for the 2015-2016 term, Attachment A to the Sixth Amendment. Santa Cruz METRO and Contractor agree that the total amount payable pursuant to the Sixth Amendment shall not exceed \$22,000.

The new Contract total not-to-exceed amount is \$118,000. Contractor understands and agrees that if they exceed the \$118,000 maximum amount payable under this Contract, they do so at their own risk.

Attachment B

IV. REMAINING TERMS AND CONDITIONS

4.1 All other provisions of the Contract that are not affected by this Amendment shall remain unchanged and in full force and effect.

V. AUTHORITY

5.1 Article 7 is amended to include the following language:

Each party has full power to enter into and perform this Sixth Amendment to the Contract and the person signing this Sixth Amendment on behalf of each has been properly authorized and empowered to enter into it. Each party further acknowledges that it has read this Sixth Amendment to the Contract, understands it, and agrees to be bound by it.

Signed on _____

Santa Cruz METRO –
SANTA CRUZ METROPOLITAN
TRANSIT DISTRICT

Alex Clifford, CEO/General Manager

Contractor –
AIRTEC SERVICE

David Olson, President



Approved as to Form:

Leslyn Syren, District Counsel





DATE: August 28, 2015
TO: Board of Directors
FROM: Liseth Guizar, Safety, Security & Risk Manager
SUBJECT: CONSIDERATION OF ISSUING A FORMAL INVITATION FOR BIDS FOR PURCHASE AND INSTALLATION OF ANTI-CLIMB FENCING PANELS AT THE NEW OPERATIONS FACILITY

I. RECOMMENDED ACTION

That the Board of Directors authorize the Purchasing Manager to issue a formal Invitation for Bids for Purchase and Installation of Anti-Climb Fencing Panels at the new Operations Facility.

II. SUMMARY

- The Santa Cruz Metropolitan Transit District (METRO) requires the services of an outside vendor to furnish and install anti-climb fencing panels at the new Operations Facility.
- The Construction Management Team from Hill International projected that the cost of anti-climb infill panels will be approximately \$46,000.
- The response to the Request for Quote provided by Lewis C. Nelson and Sons, Inc. is significantly higher than the projected amount.

III. DISCUSSION/BACKGROUND

The perimeter of the new Judy K. Souza Operations Building is surrounded with chain-link fencing, which extends along the adjacent fueling facility. Chain-link fencing alone provides minimal security coverage, as it is easily cut and can be scaled without much difficulty.

In order to enhance the security of both the Operations and the Fuel/Wash facilities on River Street, recommendations were made to improve the fencings in accordance with the American Public Transportation Association (APTA) Recommended Practices for access control systems at transit facilities. Such improvements include the addition of barbed wire and anti-climb paneling to the existing fencing.

The Construction Management (CM) Team from Hill International conducted an analysis of the cost to add anti-climb paneling to the existing fencing. Anti-climb panels are designed to decrease the opportunities to cut through the fencing and make it more difficult to attain a foothold or a handgrip for climbing over the

fence. It was estimated that such enhancement would cost approximately \$46,000.

Hill International submitted a Request for Quotation to Lewis C. Nelson and Sons, Inc., who provided a quote for \$110,862, almost two and a half times more than the projected cost. The CM Team is confident that if METRO invites a bid for proposals on the anti-climb panels, the bids will reflect the original projected cost of \$46,000.

Staff is recommending the issuance of a formal Invitation for Bids for Purchase and Installation of Anti-Climb Fencing Panels at the new Operations Facility.

IV. FINANCIAL CONSIDERATIONS/IMPACT

This action will authorize the initiation of a procurement estimated to result in a contract with a value of \$46,000. The funding for this project will be provided by the CalOES Transit Security Grant within the MetroBase Project Capital Budget.

V. ALTERNATIVES CONSIDERED

- Do nothing. This is not recommended, as the existing chain-link fencing along the perimeter of the new Operations Facility is vulnerable to intrusion, particularly the rear portion of the facility which backs along the San Lorenzo River.

VI. ATTACHMENTS

Attachment A: Authorizing Resolution

Prepared By: Liseth Guizar, Safety, Security & Risk Manager
Joan Jeffries, Administrative Assistant

VII. APPROVALS:

Liseth Guizar,
Safety, Security & Risk Manager



Approved as to form:
Leslyn K. Syren, District Counsel



Approved as to fiscal impact:
Angela Aitken, Finance Manager



Alex Clifford, CEO/General Manager

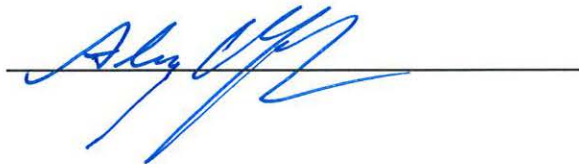

- THIS PAGE INTENTIONALLY LEFT BLANK -

Attachment A

BEFORE THE BOARD OF DIRECTORS OF THE SANTA CRUZ METROPOLITAN TRANSIT DISTRICT

Resolution No.
On the Motion of Director:
Duly Seconded by Director:
The Following Resolution is Adopted:

RESOLUTION OF THE BOARD OF DIRECTORS OF THE SANTA CRUZ METROPOLITAN TRANSIT DISTRICT AUTHORIZING THE PURCHASING MANAGER TO SOLICIT BIDS FOR PURCHASE AND INSTALLATION OF ANTI- CLIMB FENCING PANELS AT THE NEW OPERATIONS FACILITY

WHEREAS, the Santa Cruz Metropolitan Transit District has a need for Purchase and Installation of Anti-Climb Fencing Panels at the new Operations Facility;

BE IT RESOLVED BY THE BOARD OF DIRECTORS OF THE SANTA CRUZ METROPOLITAN TRANSIT DISTRICT AS FOLLOWS:

THAT, the Purchasing Manager is authorized to issue an Invitation for Bids for the services and/or supplies described above; and

THAT, the IFB is approved for release pursuant to the provisions of the Santa Cruz Metropolitan Transit District's Procurement Policy.

PASSED AND ADOPTED by the Board of Directors of the Santa Cruz Metropolitan Transit District this 28th day of August, 2015 by the following vote:

AYES: Directors -

NOES: Directors -

ABSTAIN: Directors -

Attachment A

Resolution No. _____
Page 2

ABSENT: Directors -

Approved:
Dene Bustichi, Board Chair _____

Attest:
Alex Clifford, CEO/General Manager _____

Approved as to form:
Leslyn K. Syren, District Counsel _____



DATE: August 28, 2015
TO: Board of Directors
FROM: Angela Aitken, DBE Liaison Officer
**SUBJECT: RECEIVE A SEMI-ANNUAL REPORT ON THE STATUS OF METRO'S
DISADVANTAGED BUSINESS ENTERPRISE PROGRAM**

I. RECOMMENDED ACTION

**That the Board of Directors receive a Semi-Annual Report on the status on
METRO's Disadvantaged Business Enterprise Program**

II. SUMMARY

- As a recipient of federal funds, METRO participates in the federal Disadvantaged Business Enterprise (DBE) Program as specified in Title 49, Code of Federal Regulations Part 26.
- The FTA requires METRO to recalculate its DBE goal triennially and to report goal attainment semi-annually as a requirement to receive federal funds.
- METRO's current goal for DBE participation is 1.50% of all federally funded procurements with competitive contract bidding opportunities.
- A Semi-Annual report will be provided to the Board in concurrence with the FTA reporting schedule and per METRO's DBE policy.
- Staff recommends that the Board receive this status report on the DBE Program for the first six months of Federal Fiscal Year 2015 (FFY15), 10/1/14 – 3/31/15.

III. DISCUSSION/BACKGROUND

The Department of Transportation established a Disadvantaged Business Enterprise (DBE) Program in 1980 to ensure that firms competing for federally funded contracts are not subject to unlawful discrimination and to mend the impact of previous discrimination. The DBE Program seeks to increase opportunities for small, minority and women-owned businesses to participate in federally-funded projects by "leveling the playing field" to enable DBE's to compete fairly for these federally-funded contracts.

The Federal Transit Administration requires qualified recipients of more than \$250,000 annually in federal funds to implement a DBE program as specified by Title 49 of the Code of Federal Regulations, Part 26 (49 CFR 26). A DBE is a for-profit "small business concern" that is at least 51 percent owned by a woman or a racial minority. METRO will receive approximately \$5.5 million from the Federal

Transit Administration in FY16 and therefore will maintain a DBE Program. As specified in 49 CFR 26, METRO must recalculate a DBE goal triennially and report its goal attainment semi-annually.

During the previous seven years, METRO has established DBE goals ranging from 1.33% to 2.12%. Goal attainment for the period ranges from 0% to 2.05%. The table below shows the adopted annual goal and attainment for each year since 2009. The last column shows METRO's DBE contracting attainment for the first semi-annual reporting period in FFY15, 10/1/14 – 3/31/15. The 2015 FFY full-year goal attainment will be reported at the end of November when staff calculates the contracting achievements for 4/1/15 through 9/30/15. METRO's current DBE goal is 1.50% as seen in the chart below.

Santa Cruz METRO DBE Goals And Attainment 2009 - present

	2009	2010	2011	2012-2014	2015-2017*
DBE Goal	1.33%	1.73%	2.12%	1.54%	1.50%
DBE Attainment	1.00%	0.00%	0.00%	0.56%	2.05%

* 2015 - 2017 DBE Attainment is for the first-half of FFY15, 10/1/14 - 3/31/15.

In considering the relatively small values above, it's important to acknowledge the restrictions placed on DBE goal setting, attainment and reporting. First, only competitively biddable contracts with federal funding are counted in the procurement opportunities in which DBEs can participate. While METRO received approximately 12% of its FY15 operating revenue from the Federal Transit Administration, the majority of federal operating revenue is used to pay labor costs and fringe benefits; the amount available for bidding is relatively small, only 2.52% as seen in the chart below.

Santa Cruz METRO FY15 Operating Budget Contract Opportunities					
	(A) Total	(B) \$ Procurement in Operating Budget	(C) % Procurement in Operating Budget	(D) \$ FTA Operating Assistance	(E) \$ FTA Operating Assistance in Procurements (C) * (D)
FY15 Operating Budget	\$ 48,464,472	\$ 1,223,065	2.52%	\$ 5,690,364	\$ 143,604

Second, some large expenses have no contract opportunities. For example, gas, electric and water utilities are monopolies which cannot be bid. Leases and rent payments cannot be contracted, nor can subscription services, membership costs, nor travel. Third, while many businesses are owned by minorities and women, very few of these owners register as DBEs in the statewide program.

Only certified DBEs can be included for setting goals and measuring attainment. The following table below shows the federal contracting opportunities in the FY15 operating budget.

IV. FINANCIAL CONSIDERATIONS/IMPACT

The DBE Program has direct expenses of less than \$300 for publishing adds and public hearing notices, however, failure to update the goal and submit semi-annual reports would jeopardize METRO's receipt of over \$5.5 million in federal financial assistance annually.

V. ALTERNATIVES CONSIDERED

- Do not receive a semi-annual DBE Program status report. Staff does not recommend this alternative as it would jeopardize METRO receiving federal financial assistance in FY16. Staff is required to provide this information semi-annually to inform the Board of this important program per METRO's DBE policy, art. III § 3.304(G).

VI. ATTACHMENTS

None

Prepared by: Thomas Hiltner, Acting Planning & Development Manager
Erron Alvey, Purchasing Manager
Rickie-Ann Kegley, Paralegal

VII. APPROVALS:

Approved as to form:
Leslyn K. Syren, District Counsel



Approved as to fiscal impact:
Angela Aitken, Finance Manager



Alex Clifford, CEO/General Manager

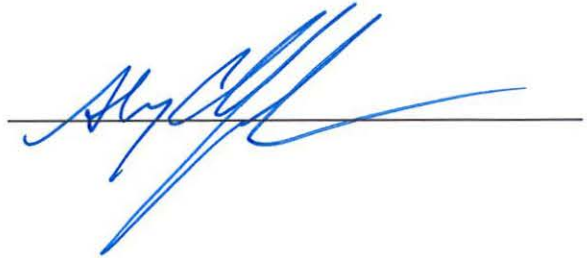



DATE: August 28, 2015
TO: Board of Directors
FROM: Alex Clifford, CEO/General Manager
SUBJECT: CONSIDERATION OF ISSUING A FORMAL REQUEST FOR PROPOSALS FOR STATE LEGISLATIVE REPRESENTATIVE SERVICES

I. RECOMMENDED ACTION

That the Board of Directors authorize the Purchasing Manager to issue a formal Request for Proposals for State Legislative Representative Services.

II. SUMMARY

- The Santa Cruz Metropolitan Transit District (METRO) requires the services of a state legislative representative to represent and advocate its positions and policies before the State Legislature and the Governor's Office.
- The contract currently in place for these services will expire on December 31, 2015, and by the terms of the contract can no longer be renewed.

III. DISCUSSION/BACKGROUND

METRO requires the services of a state legislative representative to represent and advocate its positions and policies before the State Legislature and the Governor's Office. Required services include:

- Represent METRO, as directed, before State Departments, agencies, and regulatory bodies that impact the policies and programs of METRO;
- Monitor transportation and other legislative committees as appropriate, and represent METRO before such committees, as directed;
- Advise METRO's management and Board of Directors on legislative strategy;
- Coordinate advocacy efforts with METRO's Board of Directors and staff.

The contract currently in place for these services is with Shaw/Yoder/Antwih, Inc., and is due to expire on December 31, 2015. This contract has been in effect since January 1, 2011, and all options to extend have been exercised.

Staff is recommending the issuance of a formal Request for Proposals for State Legislative Representative Services, which is anticipated to result in a contract with a 3 year base term, one 3-year option, and two 2-year options, for a total of 10 years.

IV. FINANCIAL CONSIDERATIONS/IMPACT

This action will authorize the initiation of a procurement estimated to result in a contract with a value of \$325,000 over its anticipated 10-year life. METRO has budgeted \$45,000 for the resulting contract starting January of 2016 through the end of FY17 within the Admin Department operating budget for this service.

V. ALTERNATIVES CONSIDERED

- The Board could decline to have any legislative representation at the state level.

VI. ATTACHMENTS

Attachment A: Authorizing Resolution

Prepared By: Alex Clifford, CEO/General Manager
Joan Jeffries, Administrative Assistant

VII. APPROVALS:

Approved as to form:
Leslyn K. Syren, District Counsel

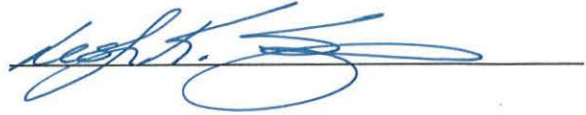

Approved as to fiscal impact:
Angela Aitken, Finance Manager



Alex Clifford, CEO/General Manager

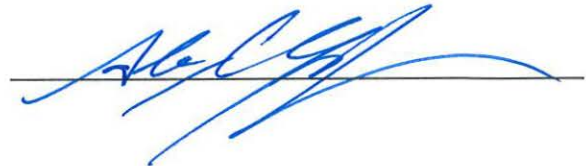

- THIS PAGE INTENTIONALLY LEFT BLANK -

Attachment A

BEFORE THE BOARD OF DIRECTORS OF THE SANTA CRUZ METROPOLITAN TRANSIT DISTRICT

Resolution No.
On the Motion of Director:
Duly Seconded by Director:
The Following Resolution is Adopted:

RESOLUTION OF THE BOARD OF DIRECTORS OF THE SANTA CRUZ METROPOLITAN TRANSIT DISTRICT AUTHORIZING THE PURCHASING MANAGER TO SOLICIT PROPOSALS FOR STATE LEGISLATIVE REPRESENTATIVE SERVICES

WHEREAS, the Santa Cruz Metropolitan Transit District has a need for State Legislative Representative Services;

BE IT RESOLVED BY THE BOARD OF DIRECTORS OF THE SANTA CRUZ METROPOLITAN TRANSIT DISTRICT AS FOLLOWS:

THAT, the Purchasing Manager is authorized to issue a Request for Proposals (RFP) for the services and/or supplies described above; and

THAT, the RFP is approved for release pursuant to the provisions of the Santa Cruz Metropolitan Transit District's Procurement Policy.

PASSED AND ADOPTED by the Board of Directors of the Santa Cruz Metropolitan Transit District this 28th day of August, 2015 by the following vote:

AYES: Directors -

NOES: Directors -

ABSTAIN: Directors -

ABSENT: Directors -

Approved:

Dene Bustichi, Board Chair

Attest:

Alex Clifford, CEO/General Manager

Approved as to form:

Leslyn K. Syren, District Counsel

- THIS PAGE INTENTIONALLY LEFT BLANK -



DATE: August 28, 2015
TO: Board of Directors
FROM: Alex Clifford, CEO/General Manager
SUBJECT: CONSIDERATION OF ISSUING A FORMAL REQUEST FOR PROPOSALS FOR FEDERAL LEGISLATIVE REPRESENTATIVE SERVICES

I. RECOMMENDED ACTION

That the Board of Directors authorize the Purchasing Manager to issue a formal Request for Proposals for Federal Legislative Representative Services.

II. SUMMARY

- The Santa Cruz Metropolitan Transit District (METRO) requires the services of a Federal legislative representative to represent and advocate its positions and policies before the U.S. Congress and the U.S. Department of Transportation.
- The contract currently in place for these services will expire on January 31, 2016, and by the terms of the contract can no longer be renewed.

III. DISCUSSION/BACKGROUND

METRO requires the services of a Federal legislative representative to represent and advocate its positions and policies before the U.S. Congress and the U.S. Department of Transportation. Required services include:

- Represent METRO, as directed, before Federal Departments, agencies, and regulatory bodies that impact the policies and programs of METRO;
- Monitor transportation and other legislative committees as appropriate, and represent METRO before such committees, as directed;
- Advise METRO's management and Board of Directors on legislative strategy;
- Coordinate advocacy efforts with METRO's Board of Directors and staff.

The contract currently in place for these services is with Capital Edge Advocacy Inc., and is due to expire on January 31, 2016. This contract has been in effect since February 1, 2011, and all options to extend have been exercised.

Staff is recommending the issuance of a formal Request for Proposals for Federal Legislative Representative Services, which is anticipated to result in a

contract with a 3 year base term, one 3-year option, and two 2-year options, for a total of 10 years.

IV. FINANCIAL CONSIDERATIONS/IMPACT

This action will authorize the initiation of a procurement estimated to result in a contract with a value of \$675,000 over its anticipated 10-year life. METRO has budgeted \$90,000 for the resulting contract starting January of 2016 through the end of FY17 within the Admin Department operating budget for this service.

V. ALTERNATIVES CONSIDERED

- The Board could decline to have any legislative representation at the federal level.

VI. ATTACHMENTS

Attachment A: Authorizing Resolution

Prepared By: Alex Clifford, CEO/General Manager
Joan Jeffries, Administrative Assistant

VII. APPROVALS:

Approved as to form:
Leslyn K. Syren, District Counsel



Approved as to fiscal impact:
Angela Aitken, Finance Manager



Alex Clifford, CEO/General Manager

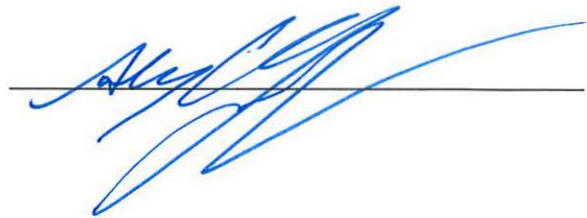

- THIS PAGE INTENTIONALLY LEFT BLANK -

Attachment A

BEFORE THE BOARD OF DIRECTORS OF THE SANTA CRUZ METROPOLITAN TRANSIT DISTRICT

Resolution No.
On the Motion of Director:
Duly Seconded by Director:
The Following Resolution is Adopted:

RESOLUTION OF THE BOARD OF DIRECTORS OF THE SANTA CRUZ METROPOLITAN TRANSIT DISTRICT AUTHORIZING THE PURCHASING MANAGER TO SOLICIT PROPOSALS FOR FEDERAL LEGISLATIVE REPRESENTATIVE SERVICES

WHEREAS, the Santa Cruz Metropolitan Transit District has a need for Federal Legislative Representative Services;

BE IT RESOLVED BY THE BOARD OF DIRECTORS OF THE SANTA CRUZ METROPOLITAN TRANSIT DISTRICT AS FOLLOWS:

THAT, the Purchasing Manager is authorized to issue a Request for Proposals (RFP) for the services and/or supplies described above; and

THAT, the RFP is approved for release pursuant to the provisions of the Santa Cruz Metropolitan Transit District's Procurement Policy.

PASSED AND ADOPTED by the Board of Directors of the Santa Cruz Metropolitan Transit District this 28th day of August, 2015 by the following vote:

AYES: Directors -

NOES: Directors -

ABSTAIN: Directors -

ABSENT: Directors -

Approved:

Dene Bustichi, Board Chair

Attest:

Alex Clifford, CEO/General Manager

Approved as to form:

Leslyn K. Syren, District Counsel

- THIS PAGE INTENTIONALLY LEFT BLANK -



DATE: August 28, 2015
TO: Board of Directors
FROM: Robyn D. Slater, Human Resources Manager
SUBJECT: EXTENSION OF PROVISIONAL EMPLOYMENT

I. RECOMMENDED ACTION

Approve an extension of provisional employment for addition Vehicle Service Workers hired during the building of the Operations Building

II. SUMMARY

- On March 3, 2013 four provisional Vehicle Service Workers (VSWs) were hired to assist in fueling and washing buses since bus parking was relocated during the building of the Judy Souza Operations Building
- As stated in the Personnel Rules and Regulations, provisional employees can work for a maximum of two year.
- As of March 3, 2015 the provisional VSWs had reached the limit of their allowable employment with METRO.
- Staff requests that the Board approve an extension of employment for the provisional VSWs until December 31, 2015 with an understanding that employment may be terminated prior to that date dependant upon METRO's needs.

III. DISCUSSION/BACKGROUND

During the construction of the Judy Souza Operations Building, bus parking was moved away from the fueling station requiring METRO to hire four provisional VSWs to insure the fleet was fueled and cleaned.

It was expected that the building would be completed and parking moved back to the operations building within the allowed employment time of two years for provisional employees.

As a result of the new timeline it is expected that the provisional VSWs will be needed beyond the two years allowed in the Personnel Rules and Regulations.

Staff requests that the Board approve an extension of employment for the provisional VSWs until December 31, 2015 with an understanding that employment may be terminated prior to that date dependant upon METRO's needs.

IV. FINANCIAL CONSIDERATIONS/IMPACT

Currently, two of the four approved provisional VSW positions are encumbered. The cost of four provisional VSW's (inclusive of benefits, excluding overtime, accrual payouts and potential workers compensation costs) is \$154,000 for six months of FY16. Funding is already allocated in the Capitol budget for the Operations Building.

V. ALTERNATIVES CONSIDERED

Do not approve the extension requiring METRO to end employment with the VSWs. Staff does not recommend this option since it is not possible to reliably fuel buses without the additional workforce.

Give direction to staff to alter the operating budget and fund two additional regular VSWs providing long term employment. Staff does not recommend this option. Once bus parking is moved back to the Operations Building the additional VSW staff will no longer be needed.

VI. ATTACHMENTS

None

VII. APPROVALS:

Robyn D. Slater, HR Manager



Approved as to form:
Leslyn K. Syren, District Counsel



Approved as to fiscal impact:
Angela Aitken, Finance Manager



Alex Clifford, CEO/General Manager

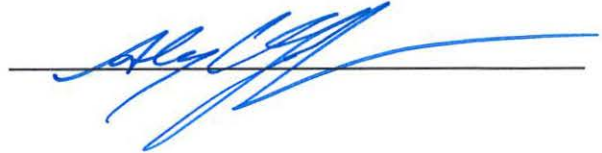

- THIS PAGE INTENTIONALLY LEFT BLANK -



DATE: August 28, 2015
TO: Board of Directors
FROM: Angela Aitken, Finance Manager
SUBJECT: CONSIDERATION OF ISSUING A FORMAL REQUEST FOR PROPOSALS FOR PURCHASE OF A FINANCIAL SOFTWARE SYSTEM AND MAINTENANCE OPTIONS

I. RECOMMENDED ACTION

That the Board of Directors authorize the Purchasing Manager to issue a formal Request for Proposals for Purchase of a Financial Software System and Maintenance Options.

II. SUMMARY

- The Santa Cruz Metropolitan Transit District (Santa Cruz METRO) has a need for a new Financial Software System with Maintenance Options
- The current System was purchased almost 20 years ago
- Only two (2) years of historical information is electronically accessible on the current system
- Excessive manual data entry is needed to use current system
- Reporting out of the current system is extremely limited and manually intensive
- Fixed Assets, Purchasing, and Budgeting modules are also being looked at to incorporate into the new financial software system

III. DISCUSSION/BACKGROUND

Santa Cruz METRO has a need for a new Financial Software System. The current System was purchased in the late 1990's, almost 20 years ago. A "front end – upgrade" eliminated the "green screen" and allowed the system to move to a Windows based front end six (6) years ago, but processes and reporting functionality were not changed nor enhanced. Finance is able to have two (2) years of financial information available electronically on the current system at one time, but no older historical information is electronically accessible on the current system; it is only available via tape backups. Excessive manual data entry is needed to use the current system, and there is no ability to scan in documentation that references financial transactions. Reporting out of the current system is limited and manually intensive. Fixed Assets, Purchasing, and Budgeting modules are also being looked at to incorporate into the new financial software system for a more efficient and integrated system.

Staff is recommending the issuance of a formal Request for Proposals for Purchase of a Financial Software System.

IV. FINANCIAL CONSIDERATIONS/IMPACT

This action will authorize the initiation of a procurement estimated to result in a contract with a value of \$250,000. \$125,000 is currently budget in the FY16 Capital Budget using Reserve funding. The remaining \$125,000 is not currently budgeted, but we are actively pursuing possible grant funding for the Financial Software system and maintenance options.

If grant funding is secured, reserve monies will not be used for this project.

V. ALTERNATIVES CONSIDERED

- The Board may choose not to issue a formal Request for Proposals to secure a financial software system contract with maintenance options. This alternative is not recommended by staff as current requests for financial information are not being met or continue to take an exorbitant amount of staff time to create.

VI. ATTACHMENTS

Attachment A: Authorizing Resolution

VII. APPROVALS:

Approved as to form:
Leslyn K. Syren, District Counsel



Approved as to fiscal impact:
Angela Aitken, Finance Manager

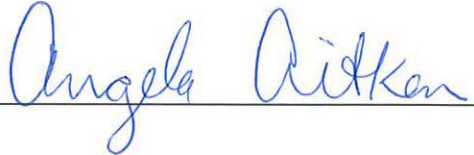

Alex Clifford, CEO/General Manager



- THIS PAGE INTENTIONALLY LEFT BLANK -

Attachment A

BEFORE THE BOARD OF DIRECTORS OF THE SANTA CRUZ METROPOLITAN TRANSIT DISTRICT

Resolution No.
On the Motion of Director:
Duly Seconded by Director:
The Following Resolution is Adopted:

RESOLUTION OF THE BOARD OF DIRECTORS OF THE SANTA CRUZ METROPOLITAN TRANSIT DISTRICT AUTHORIZING THE PURCHASING MANAGER TO SOLICIT PROPOSALS FOR PURCHASE OF FINANCIAL SOFTWARE SYSTEM

WHEREAS, the Santa Cruz Metropolitan Transit District has a need for Financial Software System;

BE IT RESOLVED BY THE BOARD OF DIRECTORS OF THE SANTA CRUZ METROPOLITAN TRANSIT DISTRICT AS FOLLOWS:

THAT, the Purchasing Manager is authorized to issue a Request for Proposals for the services and/or supplies described above; and

THAT, the RFP is approved for release pursuant to the provisions of the Santa Cruz Metropolitan Transit District's Procurement Policy.

PASSED AND ADOPTED by the Board of Directors of the Santa Cruz Metropolitan Transit District this 28th day of August, 2015 by the following vote:

AYES: Directors -

NOES: Directors -

ABSTAIN: Directors -

Attachment A

Resolution No. _____
Page 2

ABSENT: Directors -

Approved:

Dene Bustichi, Board Chair

Attest:

Alex Clifford, CEO/General Manager

Approved as to form:

Leslyn K. Syren, District Counsel



DATE: August 28, 2015
TO: Board of Directors
FROM: Anna Marie Gouveia, Fixed Route Superintendent
**SUBJECT: CONSIDERATION OF PROVISION OF A BUS, PARACRUZ VEHICLE
AND OPERATOR TO SUPPORT THE UNITED TRANSPORTATION
UNION LOCAL 23 SENIOR LUNCHEON**

I. RECOMMENDED ACTION

That the Board of Directors approve becoming an ongoing Sponsor of the United Transportation Union Senior Luncheon scheduled to be held on October 18, 2015 by providing a bus, ParaCruz Vehicle and Operator for the event and to establish this function as an annual recurring event

II. SUMMARY

- For many years the United Transportation Union Local 23 (UTU 23) has sponsored a Luncheon for Senior Citizens in Santa Cruz County.
- Eduardo Montesino, Chair, UTU 23, has informed Santa Cruz Metropolitan Transit District (METRO) that they will sponsor the Senior Luncheon this year and has scheduled the event to be held on Sunday, October 18, 2015. The location for the event is the Santa Cruz Senior Center on Market Street. UTU 23 has requested that METRO become a Senior Luncheon Sponsor by providing a bus and driver to assist riders in attending the event.
- In prior years METRO has been a Sponsor of the Senior Luncheon and has provided a bus, ParaCruz Vehicle and Operator to provide transportation services for senior citizens who would like to attend the senior luncheon, but do not have transportation services available.
- By becoming a Sponsor of the UTU 23 Senior Luncheon, METRO improves the relations with the senior riders of the system and provides a valuable benefit to citizens who rely on public transit.
- METRO will establish this recurring annual event on a future budget award basis
- If the Board of Directors wishes to terminate sponsorship of this event in the future, they can do so through the budget process
- METRO staff recommends that the Board of Directors approve the provision of a bus, ParaCruz Vehicle and Operator to assist UTU 23 in the provision of the Senior Luncheon.

III. DISCUSSION/BACKGROUND

For many years the United Transportation Union Local 23 (UTU 23) has sponsored a Luncheon for Senior Citizens in Santa Cruz County.

Eduardo Montesino, Chair, UTU Local 23, has informed METRO that they will be sponsoring the Senior Luncheon this year and has scheduled the event to be held on October 18, 2015. The location for the event is the Santa Cruz Senior Center at 222 Market St. in Santa Cruz, which does not lend itself to convenient access by users of public transit. In prior years METRO has provided a bus, ParaCruz Vehicle and Operator to provide transportation services for senior citizens who would like to attend the Senior Luncheon, but do not have transportation services available.

By becoming a Sponsor of the UTU 23 Senior Luncheon, METRO improves the relations with the senior riders of the system and provides a valuable benefit to citizens who rely on public transit service.

METRO staff recommends that the Board of Directors approve METRO becoming an ongoing Sponsor of the UTU Local 23 Senior Luncheon.

IV. FINANCIAL CONSIDERATIONS/IMPACT

The provision of a bus, ParaCruz Vehicle and Operator to support the UTU 23 Senior Luncheon would cost approximately \$800.00 per year. Funds to support this event are available in the FY16 and FY17 Bus Operator Department Operating Budget. The Operations Department will be responsible for budgeting this event on an annual basis.

V. ATTACHMENTS

Attachment A: August 17, 2015 Letter from Eduardo Montesino, Chair, UTU Local 23

Prepared By: Anna Marie Gouveia, Fixed Route Superintendent

VI. APPROVALS:

Ciro Aguirre, COO

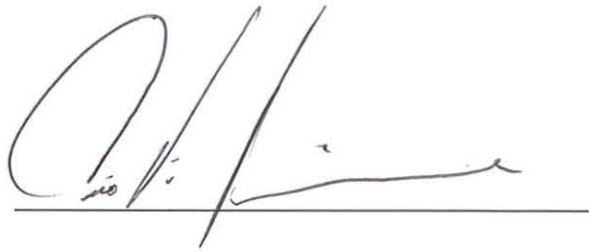

Approved as to form:
Leslyn K. Syren, District Counsel



Approved as to fiscal impact:
Angela Aitken, Finance Manager



Alex Clifford, CEO/General Manager



- THIS PAGE INTENTIONALLY LEFT BLANK -

Attachment A

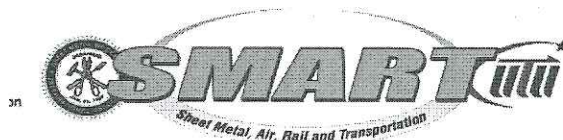

Transportation Division

August 17, 2015

Alex Clifford, CEO
Santa Cruz Metropolitan Transit District
110 Vernon Street
Santa Cruz, CA 95060

Dear Mr. Clifford,

The United Transportation Union, SMART Local 23 will be holding its annual Senior Luncheon this year on October 18, 2015.

In the past the Union honored our senior riders in the community by sponsoring a free luncheon with entertainment. Metro has participated as a supporter by allowing us the use of a bus, with specific routing along side a ParaCruz vehicle for overflow.

The United Transportation Union, SMART Local 23 would like to request the same level of service as in previous years. The Union will highlight the Districts participation both on our flyers and social media outlets.

We would like to thank you in advance for your consideration of this request in honoring the senior riders of our community.

Thank you,

A handwritten signature in black ink, appearing to read "Eduardo Montesino", with a long horizontal line extending to the right.

Eduardo Montesino

General Chairperson

UTU/SMART Local 0023



8-15A.1

- THIS PAGE INTENTIONALLY LEFT BLANK -



DATE: August 28, 2015
TO: Board of Directors
FROM: Robyn D. Slater, Human Resources Manager
SUBJECT: CONSIDERATION OF APPROVAL OF A REVISED CLASS SPECIFICATION FOR THE PLANNING AND DEVELOPMENT MANAGER

I. RECOMMENDED ACTION

That the Board of Directors approve changes to the Planning and Development Manager Class Specification

II. SUMMARY

- The newly created Planning and Development Manager Class Specification was approved January 23, 2015 as part of an organizational change creating the Planning, Grants, Governmental Affairs and Scheduling Department.
- Recruitment was conducted by the Human Resources department, resulting in two interviews but no hire.
- METRO recently hired a search firm for the recruitment process to actively source candidates.
- Due to the difficulty finding qualified candidates, the firm suggested changes to the class specification.
- Staff recommends that the Board approve the suggested revisions and incorporate them into the attached class specification.

III. DISCUSSION/BACKGROUND

At the January 23, 2015 Board meeting, CEO, Alex Clifford requested the Board approve the creation of the Planning, Grants, Governmental Affairs and Scheduling Department which included a new class specification for the Planning and Development Manager. This change aligned with CEO Clifford's November 14, 2014 alignment requests.

Recruitment was conducted by Santa Cruz Metropolitan Transit District (METRO) Human Resources which did not result in a successful candidate being hired. A search firm, KL2Connects, was recently hired by METRO. After reviewing the class specification and conducting outreach, it has been suggested to METRO that the Class Specification be revised.

The revised Class Specification with the incorporated suggestions by the search firm is attached for the Board's approval.

IV. FINANCIAL CONSIDERATIONS/IMPACT

Funding for this position in the amount of \$124,000 is included in the Planning, Grants, and Governmental Affairs Department's FY16 operating budget.

KL2Connects estimates the cost for additional advertisement (s) after the class specification is changed will be \$2,000, which will be absorbed by the year to date savings within the current FY16 budget.

V. ALTERNATIVES CONSIDERED

- Do nothing and continue to recruit using the current class specification. Staff does not recommend this option since it has been extremely difficult to find qualified candidates.
- Stop recruiting for this position. Staff does not recommend this option. This position is critical to the functioning of the Planning, Grants, and Governmental Affairs Department.

VI. ATTACHMENTS

Attachment A: Planning and Development Manager Class Specification

VII. APPROVALS:

Robyn D. Slater, HR Manager



Approved as to form:
Leslyn K. Syren, District Counsel



Approved as to fiscal impact:
Angela Aitken, Finance Manager



Alex Clifford, CEO/General Manager

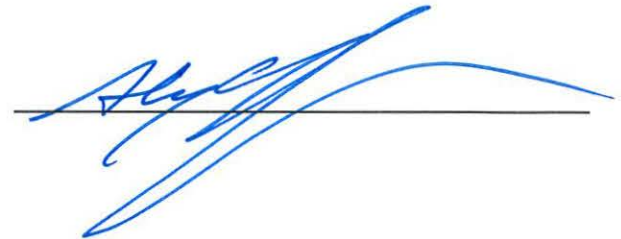

- THIS PAGE INTENTIONALLY LEFT BLANK -

Attachment A



PLANNING AND DEVELOPMENT MANAGER

DEFINITION

Under the direction of the CEO/General Manager, plans, develops, organizes and directs three distinct METRO functions: 1. Planning and scheduling (overseeing route and service development); 2. Grants (overseeing their research, review, preparation, and administration for capital and operations funding) and 3. Governmental affairs (working with local, state, and federal representatives and legislative advocates to develop and support legislation beneficial to METRO and the region). Performs other related duties as assigned.

EXAMPLES OF DUTIES

Manages the grants and legislative process including identification of funding sources, the oversight of all Federal, State, and local grant applications, and the administration of awarded grants.

Works with Federal, State, and local legislators directly, or through legislative advocates and transit organizations to develop, introduce and support legislation that improves the financial and operating ability of METRO.

Monitors Federal, State and local developments and legislation that could affect transportation and provides periodic reports to the CEO/General Manager and the Board on the effects of proposed legislation on METRO.

Makes policy recommendations to the CEO/General Manager and the Board related to proposed or existing legislation and grant opportunities for short and long term capital and operating funding strategies.

Works with staff to review statistical information regarding ridership, traffic congestion and other available data used in the formation of productivity/efficiency measurements of bus routes.

Supervises and provides direction to staff on the development and implementation of the fixed route bids. Participates in meetings with the union(s) regarding service compliance with the Collective Bargaining Agreement/Memorandum of Understanding and the service change and bidding process.

Responsible for scheduling any mandated outreach programs associated with grants, and route planning including but not limited to Title VI analysis and major services changes requiring a public hearing.

Plans, directs, coordinates, and reviews the work of department staff. Reviews and evaluates work products and develops/updates procedures and/or policies for the department and METRO in areas assigned.

Develops, administers and manages the department's annual budget. Is responsible for forecasting the funds required for staffing, equipment, training etc and then monitors and

Attachment A

approves spending to insure compliance within the authorized budget limits.

Participates in the selection, training, supervision and evaluations of staff. Establishes professional standards for work quality, quantity, performance and accountability within the department. Fosters a continuous improvement environment and sets stretch targets for team members.

Prepares written reports and presentations for staff and the Board of Directors; represents METRO at various meetings; and communicates with government officials and personnel from other transit agencies.

Develops Key Performance Indicators (KPI's), scorecards, dashboards, and other analysis tools that will assist the CEO/General Manager in his/her goals of measuring productivity, efficiencies and to set stretch goals.

EMPLOYMENT STANDARDS

Knowledge of:

- Policies, procedures and regulatory requirements governing funding programs from Federal, State, and local sources.
- Controls required by State, Federal and local funding agencies, including those that will be audited by METRO's annual outside auditor, Caltrans and in a Triennial or other FTA audit.
- Requirements for grant writing, administration, document control and budgeting.
- Principles and practices of public funding, the grant applications process, grants management and administration.
- Budget management methods for operating, short and long term capitol funding.
- Principles and practices of supervision and leadership.
- Current software programs for work processing, spreadsheets, and presentations at the intermediate level.
- Principles of transit operations and route development.
- The Development of key performance indicators, scorecards and dashboards.
- Project management, project controls and project management software.
- CEQA and NEPA regulations as they apply to transit service and projects.

Ability to:

- Direct the planning and administration of a grants program.
- Aggressively pursue potential and innovative funding options from Federal, State, and local sources.
- Investigate, analyze, evaluate, and make recommendations on complex legislative issues.
- Effectively motivate, train and evaluate the performance of staff.
- Work as part of a team to develop consensus and problem solve.
- Develop conclusions and implement policy to further the agency's mission statement by evaluating data and interacting with staff.
- Communicate effectively both orally and in writing.
- Establish and maintain effective working relationships with employees, union representatives, Board members, stakeholders, elected and appointed officials, media representatives, and members of the public.

Attachment A

TRAINING AND EXPERIENCE:

Bachelor's degree from an accredited college in business, political science, public administration, transportation planning, engineering, or a related field. Directly related experience beyond the minimum requirement may substitute for the required education based on the ratio of one and a half (1.5) years of experience for each (1) year of education.

AND

Five (5) years of recent and increasingly responsible management experience in at least one of the three areas of responsibility grant administration, route and service planning and development, or governmental affairs.

Additional training and experience desirable, but not required:

- FTA/National Transit Institute coursework.
- Certified Planner through the American Institute of Certified Planners (AICP), with Certified Transportation Planner (CTP) specialty.
- Intermediate level experience using project management software.
- Experience with construction project management and contract management.
- Experience with transit oriented development.
- Experience with full funding grant agreements and other State and Federal funding tools.
- Experience with public-private partnerships.
- Extensive knowledge of run-cutting software (HASTUS and/or Trapeze).
- Experience with air quality and sustainability concepts and laws (AB375, AB32, etc)
- Experience with CEQA and NEPA

SPECIAL REQUIREMENTS

Must be able to travel to attend meetings occurring outside the local area, including meetings that may take place at night. Must be willing to travel to Washington D.C., Sacramento and other key areas where direct legislative contact may be required.

PHYSICAL REQUIREMENTS

While performing the duties of this job, the employee is frequently required to sit, talk or hear, both in person and by telephone. Use hands to finger, handle or feel objects or controls, key and use a computer mouse. The employee is occasionally required to bend and twist at the neck, reach with hands and arms, stand, walk. Limited overhead reaching and lifting up to 20 pounds is required. Visual abilities required include close vision, distance vision, and the ability to adjust focus.

- THIS PAGE INTENTIONALLY LEFT BLANK -



DATE: August 28, 2015
TO: Board of Directors
FROM: Erich R. Friedrich, Senior Transportation Planner
SUBJECT: **CONSIDERATION OF AUTHORIZING THE CEO TO EXECUTE A ONE-YEAR EXTENSION AMENDMENT TO THE CONTRACT FOR TRANSIT SERVICES WITH THE UNIVERSITY OF CALIFORNIA, SANTA CRUZ (UCSC) BEGINNING SEPTEMBER 1, 2015.**

I. RECOMMENDED ACTION

That the Board of Directors authorize the CEO to execute a one-year Extension Amendment to the Contract for Transit Services with the University of California, Santa Cruz (UCSC) beginning September 1, 2015:

- 1) Increasing the cost per ride to \$1.39**
- 2) Increasing the bus hourly rate to \$116.66**

II. SUMMARY

- Santa Cruz Metropolitan Transit District (METRO) entered into a written Contract for Transit Services with the University of California, Santa Cruz (UCSC) on September 1, 2010.
- METRO and UCSC also executed an Extension Amendment that began on September 1, 2012, and will terminate on August 31, 2015.
- The Contract requires the cost per ride to be adjusted based upon the increase in the Consumer Price Index (CPI) on an annual basis and the bus hourly rate to reflect the marginal cost per hour of service.
- METRO and UCSC would like to extend this Contract by an additional one year as detailed in the Proposed Extension Amendment (Attachment A).

III. DISCUSSION/BACKGROUND

METRO and UCSC entered into formal agreements for transit services in the mid 1990's. A restructured Contract for Transit Services became effective on September 1, 2010 and has been extended for various terms since. The most recent Extension Amendment between METRO and UCSC began on September 1, 2012 and terminates on August 31, 2015.

The Contract requires on an annual basis that the cost per ride and Bus Hourly Rate to be adjusted based upon the increase in the Consumer Price Index (CPI). As set forth in the Extension Amendment, the cost per ride rate will increase from \$1.36 to \$1.39 based on recent CPI increases. The Bus Hourly Rate will also

increase from \$107.92 to \$116.66. This increase is above the CPI increase as both METRO and UCSC negotiated the Bus Hourly rate to reflect the true marginal cost per hour of bus service. By using the marginal cost per hour, METRO is ensured that marginal operating costs will be recouped for adding “supplemental” transit service to UCSC.

At this time METRO and UCSC would like to execute an Extension Amendment (Attachment A), setting a new cost per ride and new bus hourly rate as set forth in the attached Extension Amendment for the period of September 1, 2015 through August 31, 2016. The parties also wish to extend the term of the Contract for a period of one additional year to expire on August 31, 2016.

IV. FINANCIAL CONSIDERATIONS/IMPACT

The new cost per ride will be \$1.39 (currently \$1.36) and the new Bus Hourly Rate shall be billed at the rate of \$116.66 (currently \$107.92/hour) for the period from September 1, 2015 through August 31, 2016. Current budget revenue received from UCSC (budget line item: Special Transit Fares) is \$3.4 million as reflected in the FY16 Operating Budget. The above changes are projected to increase Special Transit Fares revenue by \$18K over the term of the Extension Amendment.

V. ALTERNATIVES CONSIDERED

- An alternative option would be to not extend the Contract, which terminates on August 31, 2015. This is not recommended by staff as METRO receives significant revenue for these contracted transit services.

VI. ATTACHMENTS

Attachment A: Extension Amendment to the Contract for Transit Services with Regents of the University of California Santa Cruz

Prepared By: Jessica Yanez, Legal Administrative Assistant
Erich R. Friedrich, Senior Transportation Planner

VII. APPROVALS:

Thomas Hiltner,
Acting Planning and Development Mgr.



Approved as to form:
Leslyn K. Syren, District Counsel



Approved as to fiscal impact:
Angela Aitken, Finance Manager

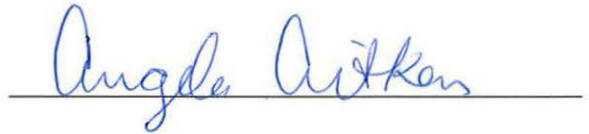

Alex Clifford, CEO/General Manager

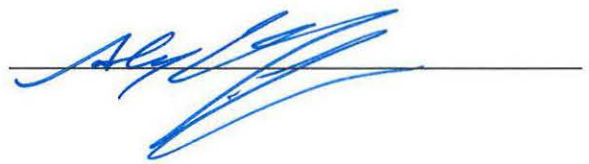

- THIS PAGE INTENTIONALLY LEFT BLANK -

Attachment A

SANTA CRUZ METROPOLITAN TRANSIT DISTRICT

EXTENSION AMENDMENT TO THE CONTRACT FOR TRANSIT SERVICES WITH REGENTS OF THE UNIVERSITY OF CALIFORNIA SANTA CRUZ

This Extension Amendment to the Contract for Transit Services is made effective September 1, 2015 between the Santa Cruz Metropolitan Transit District, a political subdivision of the State of California, ("Santa Cruz METRO"), and the Regents of the University of California, on behalf of the University of California Santa Cruz, ("University").

I. RECITALS

- 1.01 Whereas Santa Cruz METRO and University entered into a Contract for Transit Services, hereinafter "Contract" effective September 1, 2010 for a one-year initial term;
- 1.02 Whereas Santa Cruz METRO and University signed an Extension Amendment to the Contract for Transit Services, hereinafter "Extension Amendment" effective September 1, 2011 for a one-year period;
- 1.03 Whereas, Paragraph 3.02 of the Contract requires on an annual basis, beginning September 1, 2011, the cost per ride to be adjusted based upon the increase in the Consumer Price Index (CPI); and
- 1.04 Whereas, Paragraph 5.01 of the Contract allows the parties to renew the contract by the parties executing extensions to the Contract;

Now therefore, Santa Cruz METRO and University amend specific sections of the Contract by deleting the current language and implementing the language set forth below:

II. SCOPE OF AGREEMENT

There are no changes to the Contract for this section.

III. COMPENSATION

- 3.01 Santa Cruz METRO shall bill University on a monthly basis for each time a "UCSC Bus Pass" is used on a Santa Cruz METRO bus. The cost per ride shall be set at the rate of \$1.39 per ride for the period of September 1, 2015 through August 31, 2016.

IV. SUPPLEMENTAL SERVICES

- 4.03 Santa Cruz METRO shall bill the University on a monthly basis for the supplemental services provided along with the normal billing at the following rates:

A. Bus Hourly Rate.

- i. The Bus Hourly rate shall be billed at the rate of \$116.66/hour.

Attachment A

SANTA CRUZ METROPOLITAN TRANSIT DISTRICT

- ii. The Bus Hourly rate shall be billed to the University for every service hour that is provided for the supplemental service runs.
- 4.04 On an annual basis, the bus hourly rate shall be adjusted based upon the increase in the Consumer Price Index (CPI). The basis for computing the adjustment is the Consumer Price Index for All Urban Consumers (base year 1982-84=100) for San Francisco-Oakland-San Jose published by the United States Department of Labor, Bureau of Labor Statistics ("Index"). In April of each year, the most recent "Annual" index shall be compared to the "Annual" index for the previous year. The bus hourly rate currently in effect shall be increased by the percentage increase of the CPI, if any. Santa Cruz METRO shall within a reasonable time after calculating the increase, notify the University in writing of the adjusted rate which will become effective September 1st. In the event that the Index shall cease to be published, then the successor or most nearly comparable index shall be used.

V. TERM AND TERMINATION

- 5.01 This Extension Amendment to the Contract shall be for one (1) year, commencing on September 1, 2015, and shall continue through August 31, 2016. This contract may be renewed for succeeding terms by the parties executing extensions to this contract.

VI. NOTICES

- 6.01 The addresses where notices shall be sent are as follows:

UNIVERSITY:

Larry Pageler
Director, Transportation and Parking Services
University of California
MS: TAPS Carriage House
1156 High Street
Santa Cruz, CA 95064

And

Paul Schell
Interim Director, Procurement Services
University of California
2600 Delaware Avenue
Santa Cruz, CA 95064

Attachment A

SANTA CRUZ METROPOLITAN TRANSIT DISTRICT

Santa Cruz METRO:

Santa Cruz Metropolitan Transit District
110 Vernon Street
Santa Cruz, CA 95060
Attention: CEO/ General Manager

VII. MISCELLANEOUS PROVISIONS

- 7.01 Each party has full power and authority to enter into and perform this contract and the persons signing this agreement on behalf of each party has been properly authorized to enter into it. Each party further acknowledges that it has read this contract, understands it, and agrees to be bound by it.
- 7.02 All other terms and conditions of the Contract shall remain the same and each party further agrees to be bound by those terms and conditions during the Extension period.

IN WITNESS WHEREOF, the parties hereto have set their hands the day and year first written above.

SANTA CRUZ METROPOLITAN
TRANSIT DISTRICT

REGENTS OF THE
UNIVERSITY OF CALIFORNIA

BY: _____
Alex Clifford
CEO/General Manager

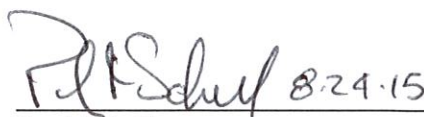
BY:  8.24.15
Paul Schell
Interim Director, Procurement Services

Approved as to form:

Approved as to form:

Leslyn K. Syren
District Counsel

Not Applicable

Counsel to University of California, Santa Cruz

- THIS PAGE INTENTIONALLY LEFT BLANK -



DATE: August 28, 2015
TO: Board of Directors
FROM: Alex Clifford, CEO/General Manager
SUBJECT: LEADERSHIP SANTA CRUZ CLASS #31

I. RECOMMENDED ACTION

Information only. No action required

II. SUMMARY

- The Leadership Santa Cruz County program provides hands-on community knowledge and experiences to approximately 25 to 50 individuals annually. Many of these individuals hold key leadership positions in the community.
- METRO has successfully participated in and sponsored the program since 2007.
- The class meets monthly from August to June.
- Santa Cruz Metropolitan Transit District (METRO) continues to be a sponsor of the program by providing a bus on three dates each program year.
- As a sponsor, up to three employees from METRO can participate in a class free of charge.
- METRO is sending Suzanne Silva, Eileen Wagley and Director Jimmy Dutra to the class this year.

III. DISCUSSION/BACKGROUND

The Leadership Santa Cruz County program provides a broad base of community knowledge and experiences to class members. Each monthly session focuses on a different essential component of the community such as housing and economics, health and human services, business and tourism, local government, the criminal justice system, agriculture, the environment, education, and art and culture. Participants interact with a wide variety of community leaders and have a hands-on experience to further their knowledge.

In 2005 METRO received a request for program sponsorship from Gary W. Smith, Executive Director of Leadership Santa Cruz County. The requested sponsorship was in the form of providing a bus for a tour of facilities, and a presentation by METRO of information about METRO's system, services, facilities and projects. The Board of Directors approved the sponsorship request and the event was very successful. The Board approves this sponsorship through the annual budget approval process.

Up to three METRO staff members participate in Leadership Santa Cruz at no cost in exchange for the bus service that METRO provides through its sponsorship. Participating in the Leadership Santa Cruz County program provides an opportunity to educate participants on the benefits of a public transit system and provides key METRO staff with local community networking opportunities.

Each year the CEO will evaluate key staff who work in a function that will benefit by this networking opportunity.

This year's attendees are Suzanne Silva, Assistant HR Manager, Eileen Wagley, ADA Eligibility Coordinator, and Board Director Jimmy Dutra.

IV. FINANCIAL CONSIDERATIONS/IMPACT

The estimated annual cost for providing the buses for the Leadership Santa Cruz County tours is approximately \$3,500 annually.

V. ALTERNATIVES CONSIDERED

- Do not sponsor the program. This is not recommended as METRO staff has benefited greatly from participating in the program.

VI. ATTACHMENTS

None

Prepared By: Alex Clifford, CEO/General Manager

VII. APPROVALS:

Approved as to fiscal impact:
Angela Aitken, Finance Manager



Alex Clifford, CEO/General Manager



- THIS PAGE INTENTIONALLY LEFT BLANK -



DATE: August 28, 2015
TO: Board of Directors
FROM: April Warnock, Paratransit Superintendent
**SUBJECT: CONSIDERATION OF APPROVING REVISIONS TO METRO'S
PARACRUZ CUSTOMER GUIDE**

I. RECOMMENDED ACTION

That the Board consider approving changes to the METRO ParaCruz Customer Guide, reflecting recommendations by the FTA and changes instituted by the Board of Directors, including consideration of door-to-curb service

II. SUMMARY

- During the Federal Transit Administration (FTA) audit in December of 2013, the auditor recommended several changes to the ParaCruz Customer Guide.
- On April 10, 2015, METRO's Board of Directors voted to institute service and fare changes to the ParaCruz service beginning September 10, 2015.
- During the Structural Deficit Workshops, one of the efficiencies identified was door-to-curb service, which could be provided upon request from an eligible paratransit rider. Door-to-curb service would **not** replace door-to-door service.
- The ParaCruz Customer guide has been revised to reflect the recommendations of the FTA auditor and the changes voted on by METRO's Board of Directors.

III. DISCUSSION/BACKGROUND

In December of 2013, METRO underwent an audit by the FTA. During the review of METRO's paratransit operations, the auditor made several strong recommendations regarding the ParaCruz Customer Guide.

Recommendations by the FTA auditor were as follows:

- Remove the policies
- Simplify the guide
- Make the guide 'reader friendly'

At the April 10, 2015 Board of Directors meeting, the Directors voted to institute several changes to METRO's paratransit service, ParaCruz. The changes will

affect fares and days and hours of service beginning September 10, 2015. Language in the Customer Guide has been amended to reflect these changes.

- Align paratransit service to the days and hours METRO's fixed route service operates, including Holidays.
- Provide paratransit during non-school term for areas served by Routes 33 and 34, at the same times as the service runs during school term service.
- Restructuring of paratransit fare structure to include an additional fare of \$2.00 for trips that would take more than one bus to travel from origin to destination when using METRO's fixed route service.
- Instituting premium fares for Will-Call returns (\$8.00) and for re-dispatching of a vehicle (\$16.00).

During the Structural Deficit Workshops, several operating efficiencies were identified. One of these efficiencies was to offer door-to-curb service, in addition to door-to-door service.

ParaCruz staff received several reports indicating there were ParaCruz customers who did not wish to be escorted to the door of their destination; they preferred to progress on their own. Currently, ParaCruz is strictly door-to-door service, and in the cases where the client does not wish to be escorted to the door of their destination, the Operator stands by and observes the client until they reach the destination on their own. Instituting door-to-curb service would have a positive effect to on-time performance by releasing the Operator to continue onto the next ride immediately after the client alights from the vehicle. Requests for curb-to-door service will be individually assessed before being approved.

At the August 11, 2015 meeting of the Elderly and Disabled Transportation Advisory Committee (E&DTAC), concerns were expressed about the possibility of leaving a person on the curb that was not cognitively able to navigate to where they needed to go. To prevent this from happening, ParaCruz would review a request for door-to-curb rides on an individual basis, and would conduct an assessment of the person to determine if the person would be eligible for this service. ParaCruz will continue to retain door-to-door as its default level of service, and offer door-to-curb as an option.

IV. FINANCIAL CONSIDERATIONS/IMPACT

The revision of METRO ParaCruz' Customer Guide would have a financial impact of approximately \$2,000 for mailing costs. Translation and printing of the Guide would be performed in-house.

V. ALTERNATIVES CONSIDERED

Do not provide approve changes to the ParaCruz Customer Guide.

VI. ATTACHMENTS

Attachment A: DRAFT METRO ParaCruz Customer Guide

Attachment B: Letter from E&DTAC dated August 19, 2015

Prepared By: April Warnock - Paratransit Superintendent

VII. APPROVALS:

April Warnock, Paratransit Superintendent April Warnock

Approved as to form:
Leslyn K. Syren, District Counsel

Leslyn K. Syren

Approved as to fiscal impact:
Angela Aitken, Finance Manager

Angela Aitken

Alex Clifford, CEO/General Manager

Alex Clifford

Draft

METRO ParaCruz Customer Guide

Santa Cruz Metropolitan Transit District's
Americans with Disabilities Act
(ADA) Complementary Paratransit Service



Quick Start Guide

1. Call ParaCruz to reserve a ride one to three days in advance. Have your ride information ready.
2. Reservation lines are open daily from 8:00am to 5:00pm.
ParaCruz Reservations:
(831) 425-4664
TTY 1-800-735-2929
3. Be ready to board the ParaCruz vehicle at any time during the **Ready Window**. The **Ready Window** begins ten minutes before your scheduled pick-up time, and ends twenty minutes after your scheduled pick-up time. A driver will wait up to five minutes for you to board the ParaCruz vehicle.
4. Pay for your ride before boarding the METRO ParaCruz vehicle. Remember to have exact fare, drivers do not make change.
5. Like METRO's fixed route bus service, ParaCruz is a shared-ride service. Expect stops along the way to pick up and drop off other clients before reaching your destination.
6. If your appointment is running late, call **ParaCruz** as soon as possible. If a ParaCruz vehicle has not yet been dispatched for your ride, the dispatcher will reschedule the pick up for a later time at no additional fare cost. If you do not call to reschedule your ride, you may be charged the premium fare for a re-dispatched ride (\$16)
7. Cancel rides you will not be taking. Call **ParaCruz** at least one hour prior to your scheduled ride to avoid a "no-show."

METRO ParaCruz Customer Guide

Table of Contents	Page
MEETING OUR CUSTOMERS' TRAVEL NEEDS	5
APPLYING FOR METRO PARACRUZ SERVICE.....	6
VISITORS	7
SERVICE AREA AND SERVICE HOURS	7
FARES.....	8
RIDE INFORMATION.....	9
NO-SHOWS	12
WHEN THE VEHICLE ARRIVES.....	ERROR! BOOKMARK NOT DEFINED.
PASSENGER INFORMATION.....	13
WHEELCHAIRS AND MOBILITY DEVICES	14
ADDITIONAL <u>INFORMATION</u>	

Attachment A

METRO ParaCruz Contact Numbers

Hearing/Speech impaired: please connect through the California Relay Service by telephoning 711.

METRO ParaCruz(831)**425-4664**

METRO ParaCruz FAX.....(831)**464-5400**

Paratransit Users Advocate

Central Coast Center for Independent Living.....(831)**462-8720**

METRO's Accessible Services Program

(Mobility Training).....(831)**423-3868**

METRO Ticket and Coupon Program Specialist

(Pre-paid ParaCruz coupons).....(831) **425-3822**

METRO Fixed Route Customer Service.....(831)**425-8600**

Attachment A

Meeting Our Customers' Travel Needs

The Santa Cruz Metropolitan Transit District (METRO) provides mass public transit within Santa Cruz County. METRO operates a fleet of safe, clean, modern and accessible buses connecting people with educational, business, medical, shopping and social destinations. People with physical, cognitive and psychiatric disabilities that prevent them from using the fixed route bus system for some or all of their transportation needs may qualify for ADA complementary paratransit service (METRO ParaCruz).

Fixed Route Bus Service

All METRO buses are accessible to better serve riders who use wheelchairs or scooters, or have difficulty getting up and down the bus steps. All major stops, intersections, and connecting points are announced to help riders recognize their bus stop or points of transfer. A limited number of seats near the front of the bus are designated as priority seating for seniors and people with disabilities. Every bus is equipped with specialized equipment to securely transport customers using wheeled mobility devices. Drivers are trained to assist with securing wheeled mobility devices.

For route and schedule information and any questions about using METRO's bus service, call METRO Customer Service at **425-8600** Monday through Friday from 7:00AM to 6:00PM.

METRO's Accessible Services Program

Many customers find that our fixed route buses provide greater flexibility and independence while being less expensive than our paratransit service. Santa Cruz METRO's **Accessible Services Program** provides free individualized instruction to older adults and people with disabilities of all ages who want to learn how to:

- Ride the bus safely and confidently
- Use passenger lifts, ramps, kneeling bus steps, and other bus features
- Handle unique mobility situations
- Make connections between buses
- Obtain a **METRO Discount Photo ID Card**
- Purchase discount fare passes
- Read the **Headways Bus Rider's Guide**
- Plan your trip using METRO's website (<http://scmtd.com>)

Attachment A

For more information or to schedule training to use the bus, call the Accessible Services Coordinator at **423-3868**.

METRO ParaCruz Service

METRO ParaCruz operates to insure that people who have a physical, cognitive, or psychiatric disability that **prevents** them from making some or all of their trips on fixed route buses have equivalent access to mass public transportation comparable to our fixed route service, as required by the Americans with Disability Act of 1990 (ADA).

METRO ParaCruz is a shared ride service provided with accessible minivans and small buses. METRO ParaCruz service operates in the same areas and during the same days and hours as the fixed route bus service. Rides must be reserved at least one day in advance of the intended trip.

Applying for METRO ParaCruz Service

To apply, call METRO ParaCruz at 425-4664 and request an appointment for a transit evaluation with METRO's Eligibility Coordinator. Transit evaluations normally take about 30 minutes. If you need transportation to and from the evaluation, ParaCruz will provide a ride at no charge to you. The ride must start and end within our service area. The person who interviews you will discuss your travel abilities and needs, and answer questions you may have. METRO ParaCruz service is limited to people who have been certified as meeting the strict eligibility criteria described in the ADA. If, as a result of a disability, you can never use the fixed route bus service under any conditions, your status will be determined as **"unrestricted."**

If you can use fixed route buses for some trips, you may be determined eligible but **"restricted"** from those trips that you could make using the fixed route bus system.

If, due to unforeseeable circumstances you may need transportation before completing the eligibility process, you may be provided **"immediate need"** eligibility for up to fourteen days.

If you have a limited term condition that prevents you from using METRO's fixed route bus system, **"temporary"** eligibility is available.

For a Personal Care Attendant (PCA) to ride free with you, your need for a PCA must be determined necessary during your transit evaluation.

Attachment A

If your condition has changed since your eligibility certification and you now require an attendant, call the ParaCruz Eligibility Coordinator for more information.

Once approved to use ParaCruz, a letter and ID card will be sent to you. Your ParaCruz ID card may be used when riding on METRO's fixed route bus service. Like METRO's Senior and Disabled Discount Card, a ParaCruz ID card entitles you to a discounted fare on METRO's fixed route buses.

METRO ParaCruz eligibility is good for a maximum of three years. Prior to your expiration date, you will be asked to verify:

- If your condition still prevents you from using the fixed route bus
- your contact information
- your mobility device(s).

Customers who indicate that they have had a change in their mobility or mobility device may be asked to attend another transit evaluation.

If you wish to appeal your eligibility determination for any reason, you may initiate an appeal in writing (forms are included with eligibility denials) within 60 days of the determination. Address the appeal to:

METRO ParaCruz Eligibility Department
2880 Research Park Dr, Suite 160
Soquel, CA 95073

Visitors

If you are eligible for ADA complementary paratransit services in another part of the country, you can use METRO ParaCruz for up to 21 days within a 365-day period. If you do not have this kind of eligibility because you live in an area without public transit service, you will be asked for documentation of your disability and verification of your place of residence.

Visitors seeking to ride more than 21 days within a 365-day period will need to participate in our evaluation process to continue to ride.

METRO ParaCruz Service Area and Service Hours

METRO ParaCruz service mirrors the fixed route bus service. ParaCruz operates in the same geographical areas, on the same days, and at the same time of day as the fixed route bus service operates.

Attachment A

METRO ParaCruz rides **must** begin and end within our service area, which is ¾ mile around a fixed route bus line (Commuter lines exempted)

See METRO's HEADWAYS for the most current information regarding when and where specific routes operate. <http://www.scmttd.com> .

During the summer months, METRO ParaCruz operates complementary paratransit service adjacent to fixed routes #33 and #34 on **weekdays** only, and only during the times the bus normally runs when school is in session.

You may be eligible for ParaCruz service if you live outside our service area, however, you will have to make other arrangements to travel into our service area to access ParaCruz.

METRO ParaCruz does not operate on the following holidays:

Memorial Day	Labor Day	Independence Day
Thanksgiving Day	Christmas Day	New Years Day

Fares

The one-way fare for METRO ParaCruz service is \$4.00 or \$6.00, depending on the origin and destination of your paratransit trip.

Fares are based on a 'full fare' concept, which means if a fixed route rider needed to take more than one bus to get from their origin to their destination, they would pay more than one full fare. (METRO does not provide transfers) For a paratransit trip of equal length, a second fare of \$2.00 would be paid. As such, your ride may cost up to \$6.00.

A Reservationist will inform you of the fare for each ride you reserve at the time of the ride booking. Please see Premium Fares; **page 11**, for fare information regarding will call returns and re-dispatched vehicles.

Premium Fares

Will Call Returns - \$8.00 (See **page 11** for more information)

Re-dispatched Vehicle* - \$16.00 (See **page XX** for more information)

*ParaCruz will not re-dispatch a vehicle for a trip missed that originates at a client's residence.

Fare must be paid each time, before you board the vehicle. Customers who do not pay the fare may not be transported. Fares can be paid as:

If you need to telephone METRO ParaCruz for any reason, call (831) 425-4664.

8-19A.8

Attachment A

- **Cash.** Exact fare only. **Drivers cannot make change.**
- **Pre-paid METRO ParaCruz Coupons.**
- **Combination of cash and coupons.**

Coupons are available in denominations of \$2.00 and \$4.00.

Coupons may be purchased at the METRO Center Information Booth, by mail, or from our website (mail order, credit cards only):<http://scmttd.com/fares/buy-passes-online>

METRO ParaCruz Coupons
METRO Center
920 Pacific Avenue, Suite 21
Santa Cruz, CA 95060

Reserving Rides on METRO ParaCruz

You can reserve a METRO ParaCruz ride one to three days in advance of your trip. Reservation telephones are open seven days a week from 8:00AM until 5:00PM (except holidays). Call ParaCruz at (831) 425-4664 or connect through the California Relay Service (711)

If you **must** call on a holiday to request a ride for the **next day**, you may leave a message with your ride request and the scheduler will call you back that evening between 5:00PM and 9:00PM to confirm your ride.

The reservationist will guide you through the reservation process. Please have the following information ready when you call to make a reservation:

1. Your first and last name.
 2. The date and day of the week you need to ride.
 3. The street address where you need to be picked up.
 4. The street address or a known landmark where you are going and the telephone number (if you have it) or your cell phone number. If you will be going to a large facility with several entrances), please specify the entrance where you would like to be dropped off or picked up at.
 5. The time you would like to arrive.
 6. The time you will be ready to be picked up for a return trip
- Additional information may be requested by the Reservationist.

Attachment A

The “Ready Window”

The ‘**Ready Window**’ is a 30-minute period of time that begins ten (10) minutes before your scheduled pick up time, and ends twenty minutes after your scheduled pick up time. After you have requested your trip(s), the reservationist will read your request back to you and inform you of your ready window for each one-way trip. Keep in mind when scheduling a ride, that **like the bus, METRO ParaCruz is a *shared-ride* service**. The driver may pick up and drop off other passengers while you are on board, which will take more time than a direct ride to your destination.,

The ParaCruz vehicle may arrive any time within your Ready Window.

Will-Call Returns

Please *schedule* your return trip times whenever possible. If you are taking a trip for an appointment and you do not know when you will be ready for your return trip, you may request a Will-Call return. (for a different option see ‘If your appointment is running late’ **page XX**)

To activate your will call you will need to call METRO ParaCruz at 425-4664 when you are ready for your next ride. You may have to wait up to an hour or longer for the vehicle to arrive. Will-Call returns are only available until 7:00PM. All return trips after 7:00PM require a definite pickup time that coincides with the fixed route times serving the return address location. ***The fare for a will call return is \$8.00. A Reservationist will notify you of the fare when you call to reserve your ride.***

Scheduling Multiple Trips

You may request up to three (3) round-trips per telephone call. If you have more than three trips you need to schedule, please call again later to schedule the additional trips.

Subscription Service

If you need a ride to the ***same place***, at the ***same time***, at least once a week “Subscription Service” may be a good option for you. Your rides will be automatically placed on the schedule each week with the same ready window, pick up location, and destination location.

If you are receiving Subscription Service, it is important to ***let us know in advance if you don’t need a ride on a particular day***. Call ParaCruz to cancel unneeded rides. Subscription rides for days ParaCruz does not operate will automatically be cancelled. On all other days, if you don’t cancel you may be charged with a “no show”.

Attachment A

Excessive cancellations or changes to subscription rides may result in removal from the subscription list.

How to Change a Scheduled Ride

If your plans change and you need to adjust your ride times, destinations, seating type or other aspects of your trip, call METRO ParaCruz **before** 5:00PM the day prior to your trip.

The reservationist will try to accommodate your needs. Changes to your original ride request may result in adjustment to your ready window and ride time, subject to schedule availability.

If there are circumstances beyond your control, you may request METRO ParaCruz to change pick-up times or pick-up/drop-off locations or your seating type on the day of your ride upon request.

If Your Appointment is Running Late

ParaCruz encourages clients to reserve adequate time for their errands and appointments. However, If you are still running late and do not think that you will be ready when ParaCruz is scheduled to arrive for pick-up, call ParaCruz immediately. Every effort will be made to locate the driver who has been assigned your ride, and if the driver has not been dispatched for your ride yet, dispatch will re-direct the driver in order to accommodate a later return for you.

Because schedules are set the day before, there may be a **delay of an hour or more before another vehicle is available** to accommodate your trip. ParaCruz recommends calling at least 20 to 30 minutes before the beginning of your Ready Window. If you call before the ParaCruz vehicle has been dispatched for your original scheduled time, you will not be charged the premium fare for a re-dispatched vehicle (\$16.00) Rescheduling shall be made at the discretion of ParaCruz, within it's operating restrictions. .

To Check on Your Ride

If a ParaCruz vehicle has not arrived by the end of your Ready Window, please call METRO ParaCruz and request an estimated arrival time. The dispatcher will contact the driver for you.

How to Cancel a Scheduled Ride

Call METRO ParaCruz at 425-4664 between 5:00AM and 10:30PM.

Attachment A

If you need to cancel a trip on the day of your ride, please call at least one hour before the beginning of your Ready Window. It is important to notify METRO ParaCruz in time so that the driver does not make an unnecessary trip, and so you are not considered a no-show.

No-Shows

No-shows occur when:

1. After scheduling a trip, you no longer need the ride and you fail to call and cancel at least one (1) hour before the start of your Ready Window
2. The ParaCruz vehicle arrives within the Ready Window, but the Operator cannot locate you at the requested pick-up location within five (5) minutes; or
3. The vehicle arrives within your Ready Window but you are not ready to go within five (5) minutes and you do not board the vehicle.

If you “No-Show” for the first leg of a trip, any subsequent leg or return trip will **not** be canceled automatically and may result in an **additional** “No-Show” assessment if not canceled.

ParaCruz service may be suspended for establishing a “pattern or practice” of missing scheduled trips which result in assessed “no-shows”. For additional information, go to <http://paracruz.com>

If a customer takes twenty-four (24) rides or more within a twelve (12) month period without being assessed a “No-Show”, he/she shall be allowed one round-trip ride free of charge.

Door-to-door service

Door-to-door service means that the driver will escort you from the entrance of the building you are being picked up from to the entrance of your destination.

Door-to-Curb service- upon request

Door-to-curb service means that the driver will escort you from the entrance of the building you are being picked up from, to the **curb** as close as possible to the designated entrance of your destination. Door-to-Curb service **must** be requested at the time you book your ride. If the driver has concerns about your ability to get to the door of your destination, the driver may elect to escort you.

What the Driver Will Do:

- Arrive at your pick up location and wait for up to five minutes.

If you need to telephone METRO ParaCruz for any reason, call (831) 425-4664.

8-19A.12

Attachment A

- Provide assistance from your front door to the vehicle. (If your pick up is from a skilled nursing or group facility, drivers will meet you in the main lobby.)
- Provide assistance into and out of the vehicle.
- Operate the wheelchair ramp or lift.
- Assist with all necessary securement systems
- Provide assistance with packages up to 30 pounds total. Driver must be able to load and unload them in one trip, without delaying the vehicle.
- Provide you with assistance to the street level entrance of your destination.

What the Driver Will Not Do:

- Drivers are not permitted to escort you beyond the entrance to any building
- Drivers will not go beyond the lobby of a skilled nursing or group facility
- Drivers may not go into your purse or wallet to get your fare.
- Drivers do not provide assistance loading or unloading objects over 30 pounds.
- Drivers are not allowed to lift passengers under any circumstances.
- Drivers are not permitted to take wheelchairs (over 30 pounds) up stairs or excessively steep ramps or driveways.
- ***Drivers do not accept tips.***

Personal Care Attendants

Some people need a Personal Care Attendant (PCA) to assist with personal care or tasks. Your PCA must get on and off the vehicle at the same place and time as you, and is not required to pay a fare. The driver does not provide assistance to the PCA beyond boarding and alighting from the vehicle. Some of the duties expected from a PCA are:

- Escort you to/from the door of your destination to/from the ParaCruz vehicle.
- Assist you in loading and unloading packages in excess of thirty (30) pounds without delaying the vehicle
- Assist you with portable life support equipment

Attachment A

Guests

A guest is someone you want to bring along to share the trip, not someone you must bring to assist you with personal care or tasks. You must arrange for guests at the time you book your ride. Guests must pay the same fare as you when accompanying you, and must get on and off the vehicle at the same place and time as you. You may bring one guest with you. However, any additional guests will be accommodated only if there is enough space on the vehicle.

Children

When an eligible child is traveling with an adult (who is serving as a PCA), a fare must be paid for the child and the PCA rides free. All children less than 46 inches tall must be accompanied by an adult. If traveling with an eligible fare-paying adult, children under 46 inches tall ride for free. Not more than 3 children less than 46 inches may ride free with one fare paying adult.

The California Vehicle Code requires that children under eight (8) years of age (or under four feet 9 inches (57) inches tall) must travel in an **approved child car seat or booster seat**. METRO ParaCruz has a limited number of child car seats and booster seats available. Please let the reservationist know if you need one when booking your trip. If you choose to travel using your personal car seat, METRO ParaCruz will contact you to ensure it meets the Code standards. ***An adult accompanying a child on METRO ParaCruz is responsible for the child.*** Drivers can assist with securing child car or booster seats.

Wheelchairs and Mobility Devices

METRO ParaCruz vehicles are designed to accommodate most wheelchairs and mobility aids. Wheelchairs and scooters will be secured upright in a non-reclining position, facing forward. Santa Cruz METRO allows for all mobility devices to access our vehicles regardless of weight or size, and will attempt to carry any wheelchair or mobility device that can physically and safely be accommodated on either our fixed route or paratransit equipment. As long as the device can maneuver the ramp or be picked up by the lift, and the customer can maneuver the device into the passenger area in a forward facing position for securement, boarding is permitted.

Respirators and Portable Oxygen Equipment

Portable oxygen equipment and portable respirators are permitted on METRO ParaCruz. The driver will assist you in securing this equipment on the vehicle. Drivers are not permitted, to assist you in using this equipment.

Attachment A

Service Animals

Service Animals are welcome on METRO ParaCruz vehicles. Service animals include any dog, or other animal individually trained to do work or perform tasks for the benefit of a qualified individual with a disability, including psychiatric, cognitive or mental disabilities. Service Animals must be under the full control of the owner at all times. Service Animals shall not occupy vehicles seats and must ride on the floor in either a sit or “down” position.

Pets and Companion Animals

Pets and companion animals may ride on METRO ParaCruz if they are in a carrier specifically designed for that purpose and under the full control of their owner. Drivers are not permitted to carry carriers (including the animal) heavier than 30 pounds on or off of METRO ParaCruz vehicles.

Safety Belts and Securement Devices

For your safety and security, the California Vehicle Code requires that all passengers use available restraint equipment and remain seated while riding on ParaCruz vehicles.

Packages and Personal Items

You may bring packages or personal items with you on METRO ParaCruz. No item may be greater than five (5) feet in any dimension. Drivers will assist with packages and personal items weighing no more than 30 pounds, but they must maintain sight of their vehicle. You may bring packages in excess of this limit onboard the vehicle, but you and/or your PCA or guest must be able to load and unload them in one trip and without delaying the vehicle. You may bring packages on-board in personal two-wheeled, collapsible carts.

Lost and Found Items

Lost and found items may be inquired for by calling METRO ParaCruz at 425-4664. Dispatch will update you on the status of your item.

Inclement Weather and Natural Disasters

METRO reserves the right to suspend, modify or cancel service during times of hazardous weather conditions or natural disasters which may jeopardize the safety of our passengers and employees. If service is suspended METRO ParaCruz will make every effort to contact you to advise you of service suspension.

Attachment A

Rider Courtesy

METRO has a list of common-sense rules to ensure the safety and comfort of all riders and drivers. We ask that you observe the following Rules of Conduct:

- Smoking is not permitted on, or within forty (40) feet of, the vehicles.
- Please travel fragrance free.
- No abusive, threatening, or obscene language or actions.
- No playing of radios, cassette tape players, mp3 players, or compact disc players (without earphones), or other noisy equipment while on-board.
- No operating or tampering with any vehicle equipment while on-board.

Suggestions, Comments, Compliments and Complaints

Feedback about METRO ParaCruz service is encouraged. If you have a comment or complaint about a particular trip or reservation experience, please call and ask to file a Customer Service Report. Comments about service policies may be directed to the Paratransit Superintendent by phone (831.425.4664), email (paracruz@scmttd.com) , or in writing to:

**Paratransit Superintendent
2880 Research Park Dr, Suite 160
Soquel, CA 95073**

To allow us to follow-up on your comments or suggestions, please be specific and provide us with the following information:

- Your name, mailing address, and telephone number.
- The date, time, and location of the incident.
- An account of your concern

All Customer Service Reports will be investigated and you will be provided with the findings of your report within thirty (30) days.

Advisory Bodies and Public Participation

The METRO Advisory Committee (MAC) and the Elderly and Disabled Transportation Advisory Committee (E&DTAC) are the officially recognized advisory bodies for METRO ParaCruz service.

MAC meetings are held once a month and are open to the public. For more information, contact the Executive Assistant at (831) 426-6080.

Attachment A

E&DTAC meetings meet on the second Tuesday of even numbered months. For more information, contact the Santa Cruz County Regional Transportation Commission by phone at (831) 460-3200 or email – info@sccrtc.org

Paratransit Users Advocate

The Paratransit Users Advocate is available to assist customers with addressing METRO ParaCruz service issues.

If you require assistance, you may contact the Paratransit Users Advocate at:

Central Coast Center for Independent Living (CCCIL)

1395 41st Avenue, Suite B

Capitola, CA 95010

Email: CCCIL@cccil.org

Website: www.cccil.org

Phone: 831-462-8720

- THIS PAGE INTENTIONALLY LEFT BLANK -



Attachment B

SANTA CRUZ COUNTY REGIONAL TRANSPORTATION COMMISSION

1523 Pacific Ave., Santa Cruz, CA 95060-3911 • (831) 460-3200 FAX (831) 460-3215 EMAIL info@sccrtc.org

August 19, 2015

Dean Bustichi, Chair Board of Directors
Santa Cruz Metropolitan Transit District
110 Vernon St.
Santa Cruz, CA 95060

RE: Revisions to ParaCruz Customer guide

Dear Board of Directors and Chair Bustichi:

The Elderly & Disabled Transportation Advisory Committee (E&D TAC) advises the Santa Cruz County Regional Transportation Commission (RTC), the Santa Cruz Metropolitan Transit District (Metro), and other service providers on transportation needs for people with disabilities, seniors and persons with limited means.

At its meeting on August 11, 2015 the E&D TAC reviewed the draft version of the revised ParaCruz customer guide. The purpose of this letter is to request that Santa Cruz Metro continue its "door-to-door" service and not introduce a "door-to-curb" option, even if requested by customers. The Elderly and Disabled Transportation Advisory Committee (E&D TAC) has strong concerns for the safety of people with cognitive impairments, which are hard to assess and can change quickly.

For instance, customers with early or undiagnosed dementia, could appear fully coherent in conversation, yet may easily become disoriented or lost when trying to find their way from the paratransit vehicle to their destination. Several committee members recounted past incidents where people did become lost, explaining the heart break of participating in the search party or bringing bad news to family members. Other committee members who regularly evaluate those facing the early stages of dementia in their professional capacities explained how difficult it is to make such a diagnosis and how rapidly a person's condition and capability can change. While Metro drivers and staff get to know regular customers and serve them well, they are not trained to diagnose dementia or recognize changes in its status. Members expressed concern that this policy could place undue burden and/or liability on well-meaning Metro drivers and intake staff.

It was suggested that by allowing "door-to-curb" service, the minimum ADA requirement, ParaCruz service would be more efficient because a driver would not be required to take the extra 5 minutes to escort each passenger to the destination building. In its discussion the committee noted Metro's past history of providing great customer service, going above and beyond the minimal amount of assistance and interaction required. It was also noted that under the current policy, many drivers would wait by the vehicle and watch to insure that passengers safely reached their destination. Such a response does allow passengers to independently go into a building while providing the opportunity for a driver to intervene if a passenger should become disoriented or lost.

Improvement in efficiency is not worth the potential risk to passenger safety, or grief experienced by families and Metro staff or potential liability resulting from any passenger failing to safely reach his or her destination.

Attachment B

The Elderly & Disabled Transportation Advisory Committee urges Metro to continue to provide "door to door" service for all ParaCruz customers, keeping everyone safe, and leaving rules and guidelines clear and easy to follow by Metro drivers and staff.

Sincerely,

A handwritten signature in black ink, appearing to read "Veronica Elsea".

Veronica Elsea, Chair
Elderly and Disabled Transportation Advisory Committee

Cc: Alex Clifford, CEO and General Manager

\\rtcserv2\internal\e&dtac\letters-outgoing\2015\2015-aug-metro-door2door.docx



THE BOARD OF DIRECTORS PROUDLY PRESENTS THIS

CERTIFICATE OF APPRECIATION

To

ERRON A. ALVEY
PURCHASING MANAGER

FOR THE COMPLETION OF **10 YEARS OF SERVICE**
BETWEEN 2005 AND 2015.

GIVEN THIS 28TH DAY OF AUGUST 2015.



CHAIR, BOARD OF DIRECTORS



CEO/GENERAL MANAGER



THE BOARD OF DIRECTORS PROUDLY PRESENTS THIS

CERTIFICATE OF APPRECIATION

To

LISETH GUIZAR
SAFETY, SECURITY AND RISK MANAGER

FOR THE COMPLETION OF 10 YEARS OF SERVICE
BETWEEN 2005 AND 2015.

GIVEN THIS 28TH DAY OF AUGUST 2015.

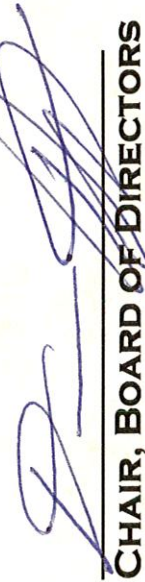

CHAIR, BOARD OF DIRECTORS



CEO/GENERAL MANAGER



THE BOARD OF DIRECTORS PROUDLY PRESENTS THIS
CERTIFICATE OF APPRECIATION

TO

FRANCISCO F. ESTRADA
BUS OPERATOR

**FOR THE COMPLETION OF 15 YEARS OF SERVICE
BETWEEN 2000 AND 2015.**

GIVEN THIS 28TH DAY OF AUGUST 2015.



CHAIR, BOARD OF DIRECTORS



CEO/GENERAL MANAGER



THE BOARD OF DIRECTORS PROUDLY PRESENTS THIS

CERTIFICATE OF APPRECIATION

TO

MARISELA MENDOZA
VEHICLE SERVICE WORKER II

FOR THE COMPLETION OF 15 YEARS OF SERVICE
BETWEEN 2000 AND 2015.

GIVEN THIS 28TH DAY OF AUGUST 2015.

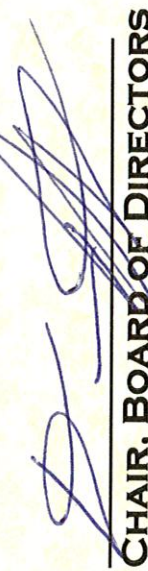

CHAIR, BOARD OF DIRECTORS



CEO/GENERAL MANAGER



THE BOARD OF DIRECTORS PROUDLY PRESENTS THIS

CERTIFICATE OF APPRECIATION

To

SHAWN O'DONNELL

FLEET MAINTENANCE SUPERVISOR

FOR THE COMPLETION OF 15 YEARS OF SERVICE
BETWEEN 2000 AND 2015.

GIVEN THIS 28TH DAY OF AUGUST 2015.

CHAIR, BOARD OF DIRECTORS

CEO / GENERAL MANAGER



THE BOARD OF DIRECTORS PROUDLY PRESENTS THIS

CERTIFICATE OF APPRECIATION

To

JOHN THOMAS
BUS OPERATOR

FOR THE COMPLETION OF 15 YEARS OF SERVICE
BETWEEN 2000 AND 2015.

GIVEN THIS 28TH DAY OF AUGUST 2015.



CHAIR, BOARD OF DIRECTORS



CEO / GENERAL MANAGER



THE BOARD OF DIRECTORS PROUDLY PRESENTS THIS
CERTIFICATE OF APPRECIATION

To

ANDREW HILL
BUS OPERATOR

**FOR THE COMPLETION OF 30 YEARS OF SERVICE
BETWEEN 1985 AND 2015.**

GIVEN THIS 28TH DAY OF AUGUST 2015.



CHAIR, BOARD OF DIRECTORS



CEO / GENERAL MANAGER



THE BOARD OF DIRECTORS PROUDLY PRESENTS THIS

CERTIFICATE OF APPRECIATION

To

DARRYL S. JUAN
BUS OPERATOR

FOR THE COMPLETION OF **30 YEARS OF SERVICE**
BETWEEN 1985 AND 2015.

GIVEN THIS 28TH DAY OF AUGUST 2015.

CHAIR, BOARD OF DIRECTORS

CEO/GENERAL MANAGER



THE BOARD OF DIRECTORS PROUDLY PRESENTS THIS

CERTIFICATE OF APPRECIATION

To

MANUEL MARTINEZ
TRANSIT SUPERVISOR

FOR THE COMPLETION OF **30** YEARS OF SERVICE
BETWEEN 1985 AND 2015.

GIVEN THIS 28TH DAY OF AUGUST 2015.

CHAIR, BOARD OF DIRECTORS

CEO / GENERAL MANAGER

- THIS PAGE INTENTIONALLY LEFT BLANK -

BEFORE THE BOARD OF DIRECTORS OF THE SANTA CRUZ METROPOLITAN TRANSIT DISTRICT

Resolution No.
On the Motion of Director:
Duly Seconded by Director:
The Following Resolution is Adopted:

RESOLUTION OF APPRECIATION FOR THE SERVICES OF KEVIN WALTER AS BUS OPERATOR FOR THE SANTA CRUZ METROPOLITAN TRANSIT DISTRICT

WHEREAS, the Santa Cruz Metropolitan Transit District (METRO) was formed to provide public transportation to all of the residents of Santa Cruz County, and

WHEREAS, the provision of public transportation service requires a competent, dedicated workforce, and

WHEREAS, the METRO, requiring an employee with expertise and dedication appointed Kevin Walter to serve in the position of Bus Operator, and

WHEREAS, Kevin Walter served as a member of the Operations Department of the METRO for the time period of July 9, 2009 to July 9, 2015, and

WHEREAS, Kevin Walter provided the METRO with dedicated service and commitment during the time of employment, and

WHEREAS, Kevin Walter served the METRO with distinction, and

WHEREAS, the service provided to the residents of Santa Cruz County by Kevin Walter resulted in reliable, quality public transportation being available in the most difficult of times, and

WHEREAS, during the time of Kevin Walter's service, the METRO expanded service, improved existing and built new operating facilities, converted the fleet to a CNG propulsion system, developed accessible bus stops, improved ridership, responded to adverse economic conditions, assumed direct operational responsibility for the Highway 17 Express service and the Amtrak Connector service, and assumed direct operational responsibility for the ParaCruz service, and

WHEREAS, the quality of life in Santa Cruz County was improved dramatically as a result of the exemplary service provided by Kevin Walter.

NOW, THEREFORE, BE IT RESOLVED, that upon his retirement as Bus Operator, the Board of Directors of the METRO does hereby commend Kevin Walter for efforts in advancing public transit service in Santa Cruz County and expresses sincere appreciation on behalf of itself, the METRO staff and all of the residents of Santa Cruz County.

BE IT FURTHER RESOLVED, that a copy of this resolution will be presented to Kevin Walter, and that a copy of this resolution be entered into the official records of the Santa Cruz Metropolitan Transit District.

PASSED AND ADOPTED this 28th Day of August, 2015 by the following vote:

AYES: Directors -

NOES: Directors -

ABSTAIN: Directors -

ABSENT: Directors -

Approved:

Dene Bustichi, Chair

Attest:

Alex Clifford, CEO/General Manager

Approved as to form:

Leslyn K. Syren, District Counsel



DATE: August 28, 2015
TO: Board of Directors
FROM: Erich R. Friedrich, Senior Transportation Planner
SUBJECT: CONSIDERATION TO ADOPT THE BUS STOP GUIDE

I. RECOMMENDED ACTION

That the Board of Directors consider and adopt METRO's updated Bus Stop Guide.

II. SUMMARY

- Santa Cruz Metropolitan Transit District (METRO) Staff found a need to update and consolidate documentation regarding bus stop location, modification and removal.
- The Bus Stop Guide is a technical document for both METRO Staff and outside parties that provides procedures and standards for bus stop design, ADA standards and amenities.
- This document will be updated periodically as needs change.
- METRO Staff recommends that the Board of Directors consider and adopt the Bus Stop Guide.

III. DISCUSSION/BACKGROUND

In 2014, METRO staff reviewed procedures and standards for bus stop installation, modification and amenity uses. The conclusion of the review was that METRO needed to update and consolidate its documentation regarding bus stops.

The Bus Stop Guide is a technical document that provides clear design criteria, procedures and standards on bus stops to both METRO staff and outside parties. It is a tool to help METRO manage its network of bus stops throughout Santa Cruz County. This technical document ensures that as bus stop improvements take place, those improvements are uniform and are prioritized based on clear guidance.

METRO staff used current practice and peer documents to craft this Bus Stop Guide. The Bus Stop Guide includes a development check list for local municipalities to follow for incorporating public transit into land use planning and roadway improvements. METRO staff will work with local jurisdictions to incorporate the checklist into the routine permitting process currently used to approve developments.

The document is sectioned as follows:

1. Procedures for Public and Private Developers
2. Bus Stop Placement and Design
3. ADA Standards
4. Bus Stop Elements and Amenities
5. On-Street Design
6. Transit-Friendly Design
7. Appendix

This first version is intended to reflect current practice and consolidate all procedures and standards into one document. However, the Bus Stop Guide is intended to be a 'living document' and it is anticipated to be periodically updated as new industry best practices develop, new equipment or amenities become available or other changes as needed arise. METRO Staff is recommending that the Board of Directors consider and adopt the Bus Stop Guide. Following adoption, planning staff will work with the local jurisdictions to have the Bus Stop guide incorporated into their permit checklist.

IV. FINANCIAL CONSIDERATIONS/IMPACT

The Bus Stop Guide was developed using internal staff time. There is no financial impact at this time.

V. ALTERNATIVES CONSIDERED

- Do not adopt the Bus Stop Guide. This is not recommended because current documentation regarding bus stop issues is outdated, contradictory, and does not reflect best practices.

VI. ATTACHMENTS

Attachment A: Santa Cruz METRO Bus Stop Guide

Prepared By: Erich R. Friedrich, Senior Transportation Planner

VII. APPROVALS:

Thomas Hiltner,
Acting Planning Manager



Approved as to form:
Leslyn K. Syren, District Counsel



Approved as to fiscal impact:
Angela Aitken, Finance Manager



Alex Clifford, CEO/General Manager



- THIS PAGE INTENTIONALLY LEFT BLANK -

Attachment A

SANTA CRUZ METRO

Bus Stop Guide

Administrative Draft

Santa Cruz METRO Planning Department



An internal resource for Santa Cruz METRO and a procedural guide for municipalities and developers.

Attachment A

Table of Contents

Introduction.....	4
Purpose:	4
Goals:	4
1. Procedures for Public and Private Developers.....	6
1.1 Technical Review and Assistance	6
1.2 Site Plan Review	7
1.3 Transit Routes and Modifications/Detours.....	8
1.4 Requests for Bus Stop Removal, Relocation, Addition, or Modify	8
1.5 Review of Bus Stop Additions, Removals, Relocation, and Amenity Changes.....	8
2. Bus Stop Placement and Design.....	10
2.1 Placement of Bus Stops.....	10
2.2 Bus Stop Spacing	13
2.3 Installation Considerations	13
2.4 Safety Considerations	13
2.5 Other Placement Considerations	14
3. ADA Standards	15
3.1 ADA Waiting or Accessory Pad.....	15
3.2 Obstacles	16
3.3 Surfaces.....	16
4. Bus Stop Elements and Amenities	17
4.1 Bus Stop Hierarchy & Amenity Standards.....	17
4.2 Bus Stop Amenities – Curbside Design	18
4.2.1 Shelters:	18
4.2.2 Benches and Simme Seats	19
4.2.3 Trash Receptacles	21
4.2.4 Signs and Sign Posts	21
4.2.5 Lighting.....	21
4.2.6 Bicycle Racks	22
5. On-Street Design	23
5.1 Lane Width	24
5.2 Roadway Grade.....	25

Attachment A

5.3 Roadway Pavement	25
5.4 Concrete Bus Pads.....	25
5.5 Typical Bus Turning Radii	26
5.6 Street-side Dimensions	27
5.7 Bus Bays	29
6. Transit-Friendly Design	31
7. Appendix	31

Santa Cruz METRO Bus Stop Guide

Introduction

Purpose:

This manual is intended to act as both an internal resource for SANTA CRUZ METRO and as guidance for municipalities and developers to create and review development proposals to ensure that they are consistent with SANTA CRUZ METRO standards for providing adequate accessibility and amenities at bus stops.

In general, SANTA CRUZ METRO is solely responsible for the siting and installation of new bus stops, whether those stops are simply a signpost in the ground, a passenger shelter, or a transit hub with enhanced passenger amenities. SANTA CRUZ METRO staff members provide initial recommendations regarding where bus stops will be placed and what amenities, if any, will be installed. SANTA CRUZ METRO then works with the appropriate jurisdiction to obtain permits for the installation of the bus stop and determines the final location. If SANTA CRUZ METRO constructs concrete passenger pads or shelters at a bus stop, it is responsible for ensuring that the bus stop meets all federal and local regulations, including those associated with the Americans with Disabilities Act (ADA).

While it is SANTA CRUZ METRO's role to provide public transit service and install bus stops in Santa Cruz County, it is generally the role of municipalities and developers to provide infrastructure for pedestrians, motorists, and bicyclists to access that transit service. Thus, when new development or redevelopment occurs at or near an existing SANTA CRUZ METRO bus stop location, it is the developer's (or municipality's) responsibility to ensure that the bus stop can be adequately served by SANTA CRUZ METRO's transit vehicles and easily accessed by transit customers. Adherences to the Americans with Disabilities Act (ADA) guidelines as well as roadway design standards are important to providing access to transit.

SANTA CRUZ METRO encourages developers to take existing and proposed bus stops into account from the beginning of the planning and design processes. Developers and local officials should seek the guidance of SANTA CRUZ METRO staff in making design decisions on development and local infrastructure that affects transit stops. Please note, however, that it is the responsibility of the developer to ensure that all construction and design regulations are met, particularly when they are more stringent than SANTA CRUZ METRO guidelines.

Goals:

- ❖ Bus stops should be placed in convenient locations that do not compromise the safety of customers, pedestrians, bicyclists, or vehicles.
- ❖ Bus stops should be spaced for optimal customer convenience that maximizes the efficient operation of transit services while not requiring riders to walk excessive distances (i.e. greater

Attachment A

- than one half mile) to the nearest bus stop.
- ❖ Bus stops should be clearly and consistently identifiable with up-to-date information for riders about services at the bus stop.
 - ❖ Bus stops should have appropriate amenities based on the usage of that stop and the surrounding land use.
 - ❖ Bus stops should be accessible. Americans with Disabilities Act (ADA) considerations will be given top priority in the location and design of new and existing bus stops.
 - ❖ Bus stops should be well-maintained and free of trash and vandalism.
 - ❖ Facilities surrounding bus stops such as roadways and pedestrian amenities should be transit-supportive and designed according to sound engineering practices.

This page is intentionally left blank

Attachment A

1. Procedures for Public and Private Developers

Land use and development affects SANTA CRUZ METRO's current and future transit services, and thus SANTA CRUZ METRO should be consulted with and involved in development projects from an early stage. SANTA CRUZ METRO staff should be involved in the design and planning of the following activities: bus stop installation or upgrades, residential and commercial developments along existing SANTA CRUZ METRO routes, and new developments that will be served by transit. SANTA CRUZ METRO staff will work with developers, businesses, and municipalities to integrate transit design features in development plans and to identify viable transit service options if desired. SANTA CRUZ METRO staff should provide site and development plan reviews for a variety of projects. Depending on the nature and complexity of the project, SANTA CRUZ METRO staff will typically respond within 10 business days of receipt of the plans regarding any necessary changes or the possibility of follow-up meetings. It is possible that large or complex projects could take 30 days or more.

1.1 Technical Review and Assistance

SANTA CRUZ METRO offers in-house development plan and transit service reviews to municipalities, developers and others in the development community. These reviews are conducted by SANTA CRUZ METRO's Planning Department and are designed to promote the incorporation of public transportation features in both urban and suburban developments and striving for a transit-friendly integration of facilities into new and existing developments. In every municipality, development and roadway improvement plans must be review by SANTA CRUZ METRO and the standards put forth in this manual must be followed. SANTA CRUZ METRO staff will analyze such plans and, when appropriate, require design alterations to make developments more easily-served by transit, and participate in processes and meetings held by the Planning Commissions, the Board of Supervisors, and the City Councils. In order to review development plans and provide appropriate feedback, SANTA CRUZ METRO requests the following items from the developer or municipality:

- Name of the municipality or developer requesting the review
- Your contact person associated with the review
- Project name
- Type of review:
 - Advisory review (not part of a formal plan review process)
 - Development plan approval (part of a formal plan review process)
 - Requested date for SANTA CRUZ METRO response
- One paper copy and one electronic copy of the development plan, including the following at a minimum:
 - Right-of-Way Design and Construction Plans
 - Streetscaping/Landscaping Plan
 - Maintenance-of-Traffic (MOT) Plan
 - Plan Profile

Attachment A

Detailed plan information allows SANTA CRUZ METRO to identify any needs and requirements related to transit service and bus stop sites. If a site is not designed to accommodate SANTA CRUZ METRO's transit vehicles and design criteria, SANTA CRUZ METRO reserves the right to withhold transit service until necessary changes are made. This includes ADA accessibility at the bus stop level as well as vehicle access requirements such as turning radii and pavement design.

In order to determine which plans are likely to affect transit service now or in the future, or conversely not affect transit service, only development and roadway improvement plans that meet one or more of the following criteria should be reviewed:

- Projects in identified transit corridors in General, Community, or Specific Plans
- Existing streets with transit routes
- Major streets or corridors
- Major activity centers: higher density residential, commercial, industrial areas, educational facilities, medical institutions, government centers, etc,
- Streets that would logically connect existing or planned transit routes or connecting areas which have or are planned to have transit routes
- Any other project that in the municipality's opinion should be assessed for current or future transit needs

1.2 Development and Roadway Improvement Plan Reviews

SANTA CRUZ METRO will review development and roadway improvement plans to identify transit needs and opportunities and provide feedback on the designs. Ongoing communication between SANTA CRUZ METRO, the appropriate city and county, and the developer may be necessary in order to solidify details of:

- Transit routes and modifications
- Bus stop placement
- Bus stop design, including ADA-compliance and adherence to federal regulations
- Temporary reroutes and bus stops

Appendix Item A is a checklist for developers and/or municipalities to use when applying and assessing proper permits for a project. This checklist should be followed as a part of the project planning and permit application phase.

If situations occur where SANTA CRUZ METRO and the developer and/or municipality are unable to agree on proposed plans, bus stop locations, bus stop designs or amenities, or other issues, the issue is to be raised to higher levels. Normally a meeting at the director level in an attempt to resolve issues. If the issue remains, and additional meeting will be held at the Chief Executive/City Manager level. If the issue is still unresolved, representatives from the parties involved may address the issue with proper Planning/Public Works Commissions, Board of Directors and City Councils at a regular meeting.

Attachment A

1.3 Transit Routes and Modifications/Detours

Whenever a construction project will affect current SANTA CRUZ METRO transit routes, SANTA CRUZ METRO staff must be involved in reviewing plans to ensure that the routes are still serviceable by SANTA CRUZ METRO vehicles. Roadway design and streetscaping features discussed later in this document will be particularly pertinent to this review.

When development projects occur outside of SANTA CRUZ METRO's current transit routes but the developer would like for the site to be served by transit, SANTA CRUZ METRO must also be involved in the planning and design process to analyze the possibility of future transit service and provide input into how the site can be designed to best accommodate that service.

1.4 Requests for Bus Stop Removal, Relocation, Addition, or Modification

Because of the number of factors involved in decisions about bus stop locations, staff or public requests to remove, relocate, modify or add a stop along an existing line will be directed to a form entitled "Bus Stop Modification Request." Once implemented, the Bus Stop Modification Request form will be directed to METRO Planning Department staff, which will assess the request using an internal assessment form. Examples of both of these forms are attached. This form summarizes the many issues that must be considered in regards to bus stop placement or improvement that are fully detailed in the text of this document, including land use, population density, spacing, setting accessibility, transfer opportunities, ridership, and existing amenities. SANTA CRUZ METRO staff may deem it necessary to take further steps in order to make an appropriate decision, including site investigations, discussions with adjacent property owners, consultations with municipalities, or solicitation of additional public input. SANTA CRUZ METRO staff will then use the information on the assessment form, and any additional information necessary to make a recommendation whether to add, remove, modify or relocate the bus stop. That recommendation is then forwarded to SANTA CRUZ METRO's Maintenance Manager for final approval. Requestors may appeal the action by writing the SANTA CRUZ METRO's Board of Directors. Section 1.5 outlines the process for reviewing bus stop modification requests in greater detail.

1.5 Review of Bus Stop Additions, Removals, Relocation, and Amenity Changes

Periodically SANTA CRUZ METRO may make alterations to bus stops as needed or in response to a request from an outside party such as a resident, municipality, developer, etc. In order to ensure that bus stop modifications are made to be consistent with this bus stop guide, a standard review processes is outlined below:

- The person or agency making the request must fill out the Bus Stop Modification Request form. This form is then forwarded to the METRO Planning Department for review.
- The METRO Planning Department reviews:
 - Basic information about the current bus stop and/or requested bus stop (location, placement, routes served, surrounding land uses, existing conditions)

Attachment A

- Proximity to other existing or planned bus stops while attempting to maintain a minimum of 880ft between stops
 - Roadway and Right-of-Way conditions or considerations – Major arterial roads are preferred for bus stops with more amenities. A Bus Stop modification on Caltrans Right-of-Way requires encroachment permits and Caltrans design standards. Speed limits and lanes determine the need for a bus pull out or bulb out.
 - Pedestrian and ADA Accessibility conditions or considerations – sidewalks must be in good repair with minimal obstacles and appropriate width (>4ft). If the bus stop is not ADA accessible, major modifications are needed and could potentially require engineering plans, encroachment permits, and major construction.
 - Boarding counts to determine the classification of the bus stop
 - Condition of existing amenities, if any
- The Planning Department will use this assessment to make an initial recommendation to approve or deny a bus stop modification request.
 - SANTA CRUZ METRO's Maintenance Manager (or designee) will review the assessment and recommendation and make the final decision of approval or denial of a bus stop modification request.

The Bus Stop Modification Request form and the Assessment of Bus Stop Request can be found as Appendix Item B.

This page is intentionally left blank

Attachment A

2. Bus Stop Placement and Design

Construction projects that significantly alter the roadway or surrounding land uses may require a re-evaluation of the placement of SANTA CRUZ METRO bus stops. Likewise, the placement of new bus stops or relocation of existing stops due to development or construction will necessitate early involvement from SANTA CRUZ METRO staff to identify appropriate bus stop locations. A number of factors, discussed in this document, contribute to the final decisions regarding bus stop placement. During the planning process, SANTA CRUZ METRO will advise on street and site designs that best accommodate bus stops.

The design of bus stops and surrounding areas is very important to SANTA CRUZ METRO for the safety and convenience of passengers as well as for adherence to the requirements of the Americans with Disabilities Act. Bus stop design and amenities are detailed in Chapter 4 of this document, and there are several factors that influence the type of bus stop to be designed and what amenities will be included at each location. Developers should work with SANTA CRUZ METRO at the early stages of site and project planning to identify the opportunities and needs for new or altered bus stops.

Developers should work with SANTA CRUZ METRO and the municipality to design site plans that accommodate bus stop loading pads, passenger shelters, bus bulbs, bus bays, and other amenities where merited. While SANTA CRUZ METRO recognizes that certain communities and neighborhoods may want to install custom bus shelters in some locations, SANTA CRUZ METRO prefers to install its standard shelters for ADA accessibility and maintenance reasons. However, if non-standard shelters are to be installed, the design must first be approved by SANTA CRUZ METRO staff and a formal maintenance agreement will be produced. These issues are also addressed in Chapter 4.

2.1 Placement of Bus Stops

On-street bus stops are generally placed in one of three locations: far-side (located immediately after an intersection); near-side (located immediately before an intersection); and mid-block (located between intersections). The specific roadway dimensions associated with placement of bus stops are addressed further below. A general representation of the three main bus stop locations is shown below:

Each different bus stop location offers advantages and disadvantages to vehicle drivers, bicyclists, and pedestrians. These benefits and drawbacks are listed below. In general, SANTA CRUZ METRO has found that far-side bus stop locations are safer for pedestrians and facilitate faster travel times. However, it is important to note that the final decision on bus stop location is dependent on ease of operation, transfer situations, space availability, traffic volumes, and safety considerations. SANTA CRUZ METRO performs on-site evaluations of each proposed bus stop location to analyze these operating and safety conditions and identify the most appropriate bus stop location for each situation.

Attachment A

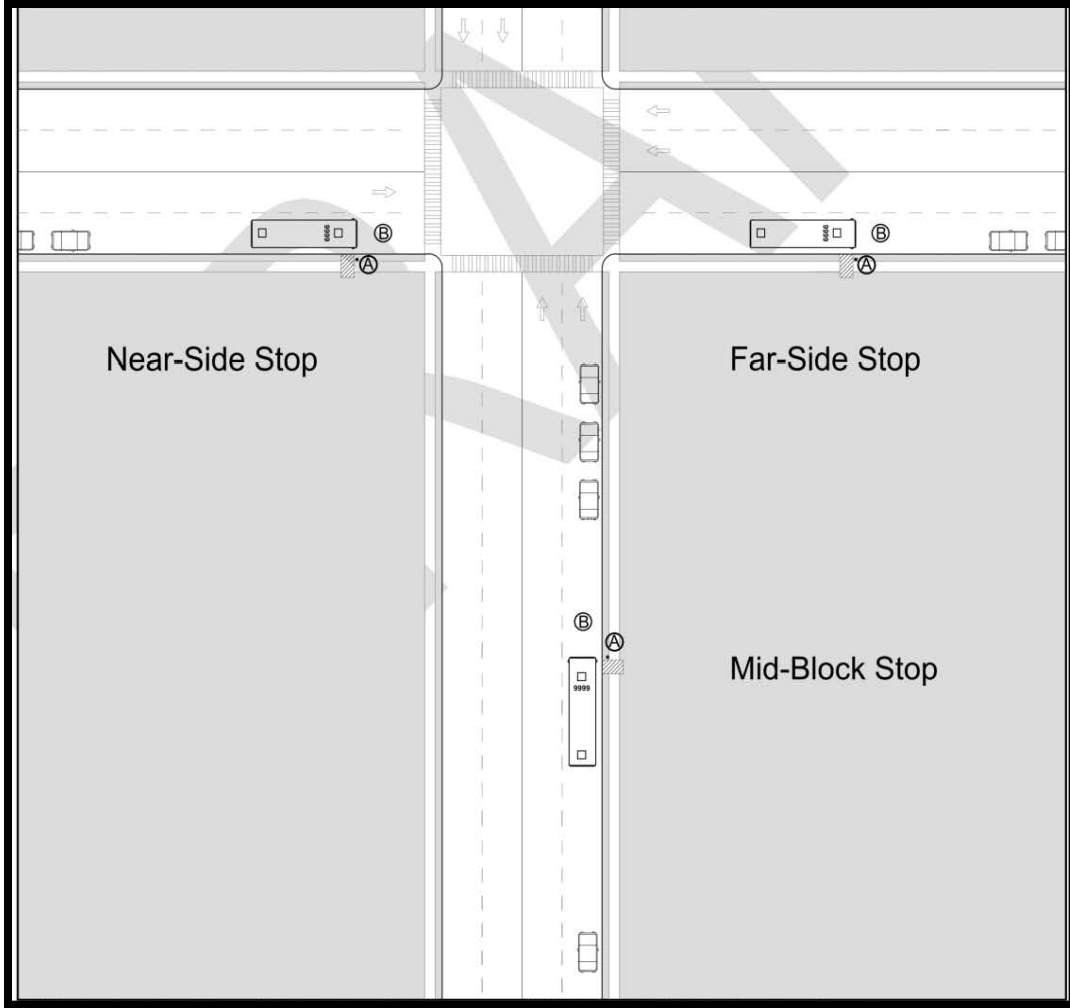

Attachment A

Location related to Intersection	Advantages	Disadvantages	Where Recommended
Far side	<ul style="list-style-type: none"> Minimizes conflicts between right-turning vehicles and buses Provides additional right turn capacity by making curb lane available for traffic Minimizes sight distance problems on approaches to intersection Encourages pedestrians to cross behind the bus Creates shorter deceleration distances for buses and minimizes area needed for curbside bus zone Results in bus drivers taking advantage of gaps in traffic flow created at traffic signals 	<ul style="list-style-type: none"> May result in intersections being blocked during peak periods by parked buses May obscure sight distance for crossing vehicles May increase sight distance problems for pedestrians Can cause a bus to stop far-side after stopping for a red light (double stopping) May increase number of rear-end accidents since drivers do not expect buses to stop again after a red light Could result in traffic queued into intersection May interfere with right-turn movement from cross street 	<ul style="list-style-type: none"> There is a high volume of turns Route alignment requires left turn immediately before stop Complex intersections with multi-phase signals or dual turn lanes Traffic is heavier on the near-side Existing pedestrian conditions are better on far-side Traffic conditions and signals may cause delays if near-side Intersections have transit signal priority treatments
Near side	<ul style="list-style-type: none"> Minimizes interference when traffic is heavy on the far side of the intersection Allows passengers to access buses closest to the crosswalk Results in the width of the intersection being available for the driver to pull away from the curb Eliminates double stopping Allows passengers to board and alight while the bus is stopped at a red light Provides driver with opportunity to look for oncoming traffic 	<ul style="list-style-type: none"> Increases conflicts with right-turning vehicles May result in stopped buses obscuring curbside traffic control devices and crossing pedestrians May cause sight distance to be obscured for cross vehicles stopped to the right of the bus May block the through lane during peak period with queuing buses Increases sight distance problems for crossing pedestrians 	<ul style="list-style-type: none"> Traffic is heavier on the far-side Existing pedestrian conditions are better than on the far-side Pedestrian movements are safer on near-side Bus route continues straight through the intersection
Mid block	<ul style="list-style-type: none"> Minimizes sight distance problems for vehicles and pedestrians May result in passenger waiting areas experiencing less pedestrian congestion May be closer to passenger origins or destinations on long blocks 	<ul style="list-style-type: none"> Requires additional distance for no-parking restrictions Encourages unsafe pedestrian crossing Increases walking distance for patrons crossing intersections, or requires special features for patrons crossing at mid-block locations 	<ul style="list-style-type: none"> When the route alignment requires a right turn and curb radius is short Problematic traffic conditions at the intersection Passenger traffic generator is located mid-block Compatible with corridor or district plan

Attachment A

2.2 Bus Stop Spacing

Bus stop spacing has a major impact on transit vehicle and system performance as well as customer ease of access. Stop spacing also affects overall travel time. In general, the trade-off is between:

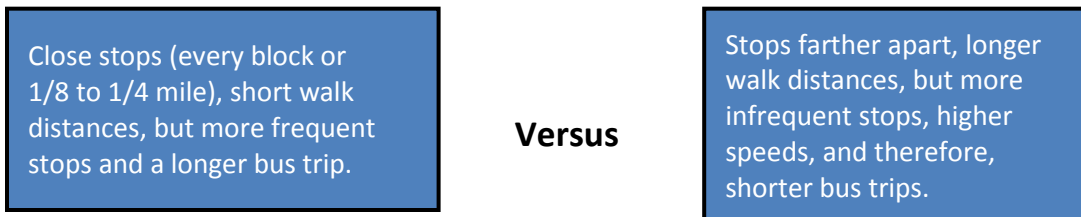

SANTA CRUZ METRO's target is to have bus stops be no less than 880 feet apart and no greater than 1,760 feet apart, depending upon whether this is in an urban or rural setting and other physical and operational constraints.

2.3 Installation Considerations

In addition to considering where a bus stop should be placed relative to an intersection, the decision to install a bus stop at a certain location should take into account the following factors:

- Adjacent land use and activities, including major trip generators and origins/destinations of potential customers
- Bus route alignment (for example, turning movements at an intersection)
- Intersecting transit routes and transfer possibilities
- Pedestrian access – accessibility should be considered in the placement of all new bus stops; though the construction of sidewalks and other pedestrian infrastructure is often beyond the control of SANTA CRUZ METRO, bus stops should be placed in accessible areas to the extent possible given existing conditions
- Existing right-of-way - wherever possible, bus stops should be located where there is adequate right-of-way space for the construction of passenger amenities
- Traffic conditions (volume and speed) and traffic control devices
- Ambient lighting, especially at night

2.4 Safety Considerations

For the safety of pedestrians as well as drivers, bus stops should not be placed in the following locations:

- Over the crest of a hill, where oncoming traffic will be unable to see a stopped bus
- Around a blind curve, where oncoming traffic will be unable to see a stopped bus
- On the side of a roadway with limited space for pedestrian movement (i.e. constrained by a ditch, guardrail, or retaining wall)
- On limited-access roads

Attachment A

2.5 Other Placement Considerations

- Bus stops should be easy to see for pedestrians, bicyclists, drivers, and bus operators
- Buses should not block residential or commercial driveways when stopped; if blocking a driveway is necessary for operational reasons, it is better to fully block a driveway rather than partially so that vehicles do not attempt unsafe maneuvers in front of or behind the stopped bus
- Bus stops should preferably be placed close to existing pedestrian crossings, good pedestrian infrastructure, and adequate lighting
- Bus stops should not be placed mid-block when not close to a protected crosswalk
- In high-transfer locations, bus stops should be located so as to minimize the intersection crossings required of transferring patrons
- In areas with on-street parking, parking restrictions will need to be put in place to ensure bus access to the curb
- Special consideration should be given to bus stop locations in residential areas without sidewalks

This page is intentionally left blank

Attachment A

3. ADA Standards

The Americans with Disabilities Act of 1990 (ADA) is broad legislation intended to make American society more accessible to people with disabilities. It consists of five sections or titles (employment, public services, public accommodations, telecommunications, and miscellaneous). Titles II and III (public services and public accommodations) affect bus stop planning, design, and construction. Although the definition of disability under the ADA is broad, bus stop placement and design most directly affect persons with mobility and visual impairments. These impairments, which relate to the more physical aspects of bus stop accessibility, have received the most attention.

3.1 ADA Waiting or Accessory Pad

A waiting or accessory pad is a paved area at a bus stop provided for bus patrons and can contain either a bench or a bus shelter. Bench and shelter amenities, such as trash receptacles or bike racks, can also be located on the waiting pad. The size of the waiting pad depends on several factors. The length and width of shelters and benches, clearance requirements for street furniture, location of wheelchair lift extension (front or back door of bus), and the length of the bus are common size-determining factors. Transit agencies, typically, have one or two accessory-pad variations to accommodate different configurations and components that may be installed.

Waiting pads are usually separated from the sidewalk to preserve general pedestrian flow. It is generally recommended that 5 feet of clearance be preserved on sidewalks to reduce potential pedestrian conflicts and limit congestion during boardings and alightings. The pad can be located on either side of the sidewalk, depending on available right-of-way space, utility poles, or buildings. In either case, a paved surface should be provided from the waiting pad to the back-face of the curb to enhance access and comfort. ADA mobility guidelines should be followed when street furniture is to be included on a waiting pad. A waiting pad should accommodate a 5-foot (measured parallel to the street) by 8-foot (measured from the back face of the curb) wheelchair landing pad that is free of all street furniture and overhangs.



Attachment A

3.2 Obstacles

Examine all the paths planned from the alighting point at the bus stop to destinations off the bus stop premises. Determine whether any protrusions exist that might restrict wheelchair movements. If protrusions exist and they are higher than 27 inches or lower than 80 inches, a person with a vision impairment may not be able to detect an obstacle (such as a phone kiosk) with a cane. A guide dog may not lead the person with the impairment out of the path. Although it may not be the transit agency's responsibility to address accessibility problems along the entire path, an obstacle anywhere along the path may make it inaccessible for some transit users with disabilities.

3.3 Surfaces

Surfaces must be stable, firm, and slip-resistant. Such provisions are beneficial for all transit users, but especially for those who have disabilities. Avoid abrupt changes in grade, and bevel those that cannot be eliminated. Any drop greater than 1/2 inch or surface grade steeper than 1:20 requires a ramp.

A full list of ADA standards for transit can be found in appendix item D-1.

This page is intentionally left blank

Attachment A

4. Bus Stop Elements and Amenities

Security, access, facility attractiveness and several other factors should be considered when establishing or updating bus stops. SANTA CRUZ METRO has authority to install and construct bus stops throughout Santa Cruz County as discussed in Section 1.5. The purpose of this section is to establish a secure, attractive, and accessible waiting area at each stop by providing guidance for appropriate amount of bus stop amenities.

4.1 Bus Stop Hierarchy & Amenity Standards

Class A - > 50 boardings per day, > 30 bus departures per day, Medium to High Residential, Office, and/or Commercial Land Use

These are the stops with high boardings per day that should have at a minimum a shelter, map and route information, and an optional bicycle rack. These stops may also need a bus pull out area if there are long dwelling times.

Class B - 15 – 50 boardings per day, 10-30 bus departures per day, Low to Medium Residential and some Commercial or Office Land Use

These stops have moderate boardings per day and should be equipped with a Simme seat or a bench. Additional amenities could include map and route information, and an optional bicycle rack depending on the location. Consideration should be given in areas with higher than average elderly and disabled populations for the installation of a shelter.

Class C - < 15 boardings per day, <10 bus departures per day Rural and/or Low Residential Land Use

These are the stops with the lowest use and should have at least a sign posted including map and route information.

If a bus stop meets the amenities criteria it may be considered for a shelter or bench and trash receptacle placement by SANTA CRUZ METRO. Meeting these criteria does not guarantee installation of any amenity. All stops are analyzed against the criteria in this section and further adjusted for amenities based on the comprehensive site review. Existing site conditions and pedestrian infrastructure, public right-of-way availability, accessibility and safety issues, and other concerns must be encompassed in a comprehensive site review and addressed before future shelter or bench placements are confirmed.

All bus stops should have:

- Adequate lighting at the stop or nearby
- ADA accessibility and pedestrian safety consideration
- A bus stop sign with stop number designation as well as map and route information

Attachment A

4.2 Bus Stop Amenities – Curbside Design

4.2.1 Shelters:

Shelters should generally be placed so that they are facing the travel lane to ensure that the bus operator can easily see the waiting passengers and that there is minimal walking distance from the waiting area to the boarding area. Shelters should not be placed within 15 feet of a fire hydrant or a ADA-accessible parking space. If a shelter is installed adjacent to a building or structure, a minimum of a 12-inch gap should be preserved to allow for trash removal and cleaning of the shelter. Finally, the location of utility access points should be taken into account when installing shelters. No matter how the shelter is placed, all shelters must meet both local jurisdictional accessibility requirements and DOT's ADA Standards:

- Maintain Clear Floor or Ground Space within Shelter: Provide a minimum clear floor or ground space of 30 x 48 inches, entirely within the shelter to accommodate wheelchair users. SANTA CRUZ METRO's standard shelter is designed for a forward approach to the Clear Floor or Ground Space. However, other shelter designs may accommodate parallel approaches.
- Include an ADA Landing Pad: When constructing a bus stop with a shelter, a 60 x 96 inch landing pad that is clear of obstructions must also be built. See the section above for more details about the ADA landing pad.
- Connect Shelter to ADA Landing Pad and Sidewalk Network: Connect the shelter to the ADA landing pad and the sidewalk network via an accessible route.
- Supply bench seats that inhibit lying down
- Use graffiti-resistant film
- Reference diagrams and appendix

Basic specifications for SANTA CRUZ METRO's preferred LNI (or equivalent) shelters are below:

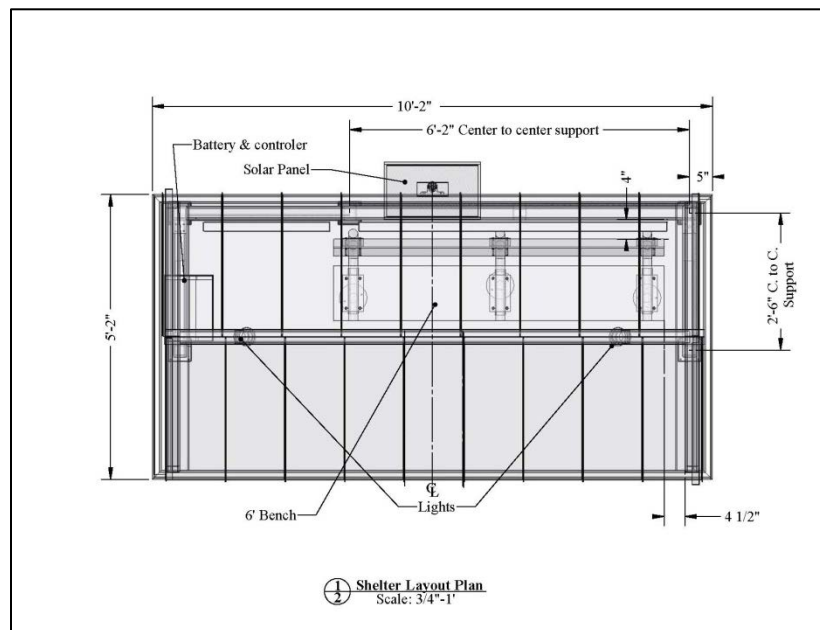

Attachment A

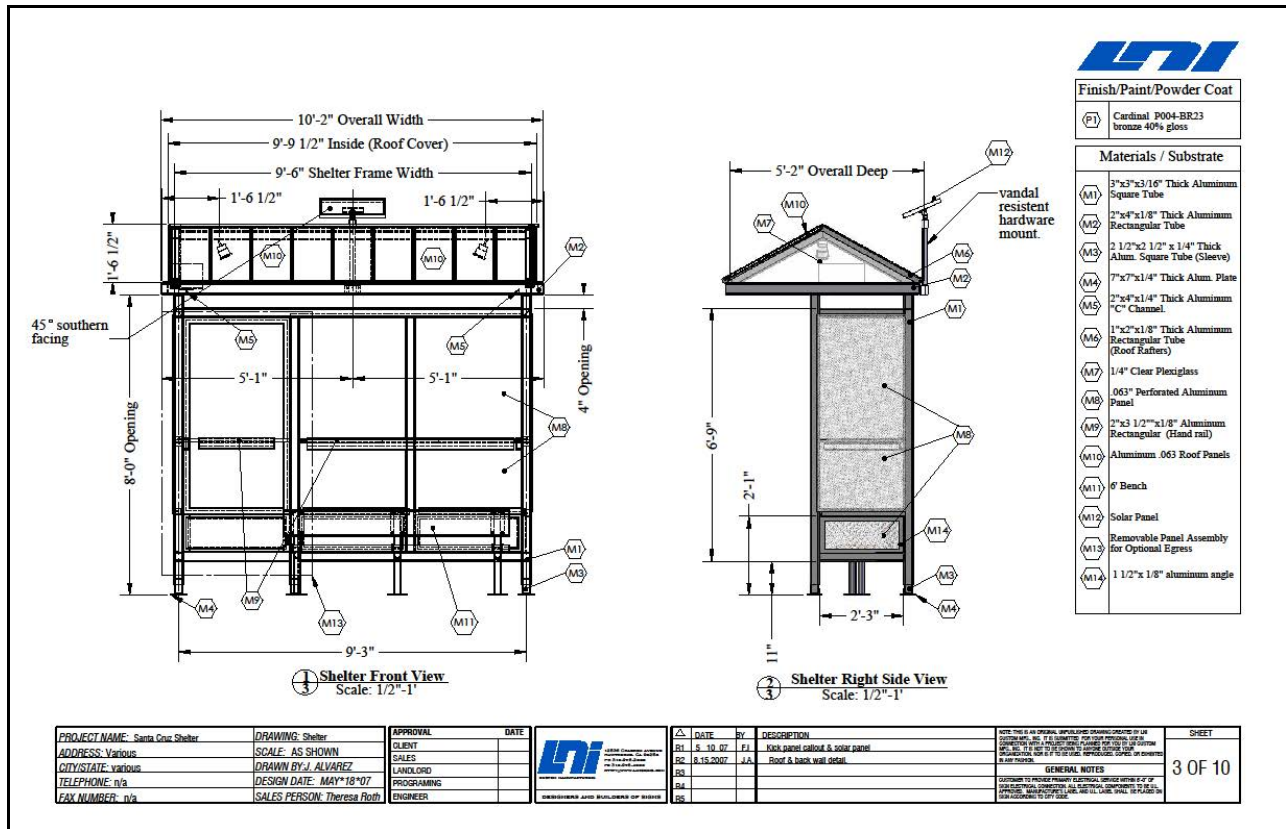

4.2.2 Benches and Simme Seats

Benches are installed inside all standard shelters. Benches may also be installed independently at bus stops that do not have shelters. Efforts should be made to locate benches near bus stops where they do not create barriers to accessible bus boarding or sidewalk usage.

The design factors for benches should include:

- Benches should be placed facing the street
- Strength and durability of structure and materials
- Resistance of materials and paint treatments to weather conditions, graffiti, cutting, fire, and other forms of vandalism
- Benches should be placed on the back side of sidewalk a minimum of six to nine feet from the bus sign post, to allow pedestrians to move past people sitting on the bench.
- Ensure that there are no conflicts with wheelchair accessibility and loading at the bus stop
- Benches should be anchored to prevent unauthorized movement.
- Benches should inhibit lying down

A Simme Seat is an alternative passenger waiting amenity that incorporates the bus stop sign pole with two seats attached at the appropriate height. This feature can be used as an alternative when bus shelters become a nuisance and attract loitering. Below is a photo and installation specs:

Attachment A

1: If at a sidewalk (lag bolted to concrete):



2: If in a remote area (need concrete footing):

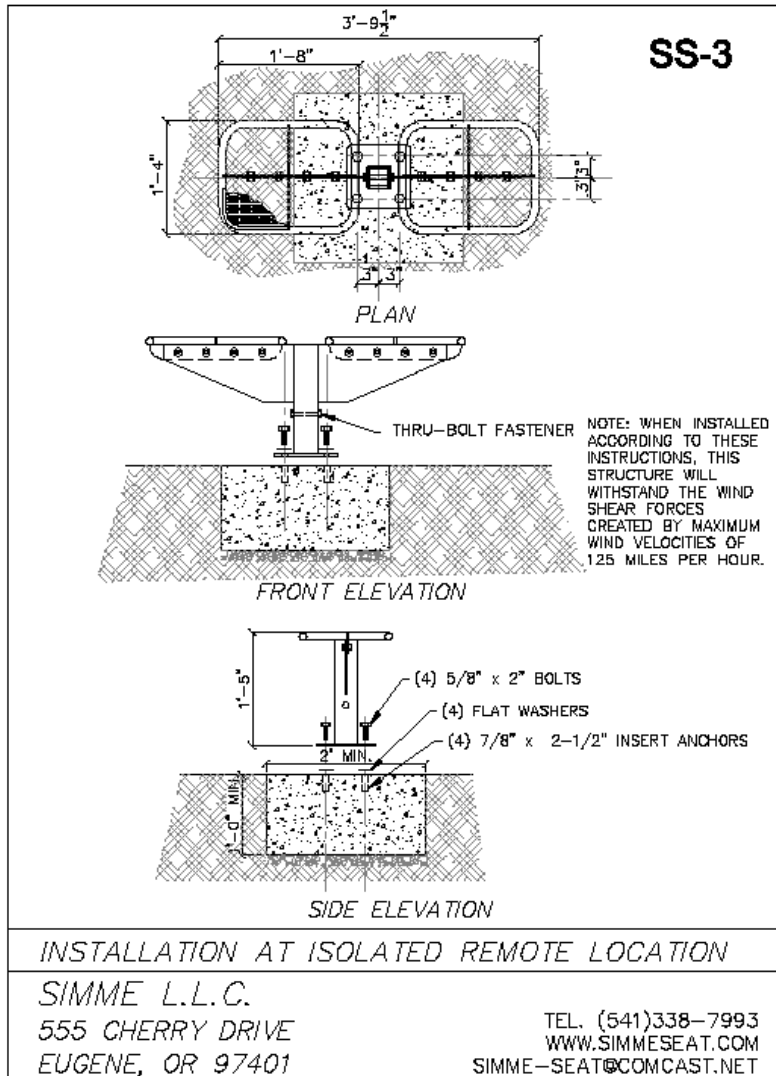

Appendix 3

Attachment A

4.2.3 Trash Receptacles

SANTA CRUZ METRO places trash receptacles at some bus stop locations with shelters, at other high-ridership stops, and at locations where litter has become problematic. SANTA CRUZ METRO will consider placement of a trash receptacle at bus stop locations with 50 or more boardings per day. Trash receptacles should be installed where they do not create an obstruction or interfere with the accessibility of the bus stop or the adjacent sidewalk. Trash receptacles shall not be placed on the wheelchair landing pad or in the clear floor or ground space within the shelter. They must not obstruct pathways between the sidewalk, shelter access (where applicable), the landing area, or posted information. The receptacles should be secured to the pavement to prevent accidental tipping or unauthorized movement.

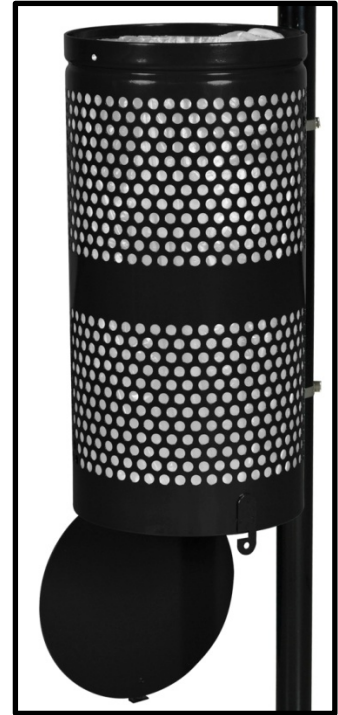

4.2.4 Signs and Sign Posts

SANTA CRUZ METRO's bus stop sign should be securely mounted on its own post at an angle perpendicular to the street. The signs should be placed at least 2 feet away from the face of curb in order to be clear of side mirrors of a bus (note also that all signs within the bus stop area, including signs installed by other parties, should be set back at least 2 feet from the face of curb).

For best visibility, bus stop signs should usually be placed 2 feet from the face of curb and no further than 4 feet away from the face of curb so that they are still clearly visible to patrons and bus drivers. However, the exact distance of the sign from the curb will vary depending on site conditions, and only in limited circumstances shall the sign be placed beyond the 4' desired limit and in a location where it is visible to the bus operator.



4.2.5 Lighting

Adequate lighting at bus stop facilities allows bus drivers and approaching traffic to see waiting passengers at night. Lighting also provides added security for those waiting at the stop, in addition to illuminating route and schedule information for patrons. Lighting can be provided by a nearby streetlight, ambient light from the adjacent businesses, lighting installed within the shelter, or a stand-

Attachment A

alone light pole. Transit stops without sheltered lighting should be located within 50 feet of an overhead light source. Bus stop light fixtures or shelter illumination should be between 1.5 to 2.0 foot-candles. However, shelter lighting should be on the lower range as to not create a spotlight affect that makes it difficult for passengers waiting inside the shelter to see outside.

4.2.6 Bicycle Racks

SANTA CRUZ METRO will incorporate bicycle racks into the design of SANTA CRUZ METRO-owned facilities such as park & rides and transit centers and when developing or renovating these locations. Municipalities and other parties may install bicycle racks near bus stops, as long as they do not obstruct or interfere with the accessibility of the bus stop or adjacent sidewalk. Bicycle racks should never be placed on the wheelchair landing pad, within the shelter, or blocking access from the shelter to the boarding area or access to the sidewalk network. Bicycle racks installed should conform to municipal standards.

Basic guidelines for curb side placement of bus stop amenities can be found as Appendix Item C.

This page is intentionally left blank

Attachment A

5. On-Street Design

The size, weight, and operational characteristics of transit vehicles require special consideration in the design and construction process. Site layout and roadway design should incorporate the bus design and operational characteristics described in this manual. Proper design will enhance bus operations and traffic flow, help maintain roadway surfaces, and reduce obstacles for motorists, bicyclists, pedestrians, and bus operators.

Factors that should be considered when designing a site that will be served by SANTA CRUZ METRO transit vehicles include:

- anticipated vehicle speeds
- traffic volume
- on-street parking conditions
- intersection radii
- bus dimensions
- presence of bicycle lanes
- sight distances
- land uses and surrounding development types (urban/rural)

The majority of SANTA CRUZ METRO's bus stops are on-street bus stops that occur in the curb lane, a shoulder, or a parking lane. Dedicated transit facilities such as bus turnouts, bulbs, and turnarounds can also be incorporated into roadway designs to provide safe, off-street service points that do not interfere with traffic movement and help promote a vehicle's safe re-entry into traffic. These facilities should be designed to accommodate all of SANTA CRUZ METRO's transit vehicles and allow for necessary vehicle acceleration and deceleration. Developers must contact SANTA CRUZ METRO in the early stages of design and development before the installation of any type of bus stop. General illustrations of the different types of possible street-side bus stops are included below.

The remainder of this chapter will be divided into sections that provide more specific information on the following subjects:

- General street design to accommodate transit vehicles
- Design of on-street bus stop zones
- Design of dedicated bus facilities (turnouts, bulbs, and turnarounds)

Attachment A

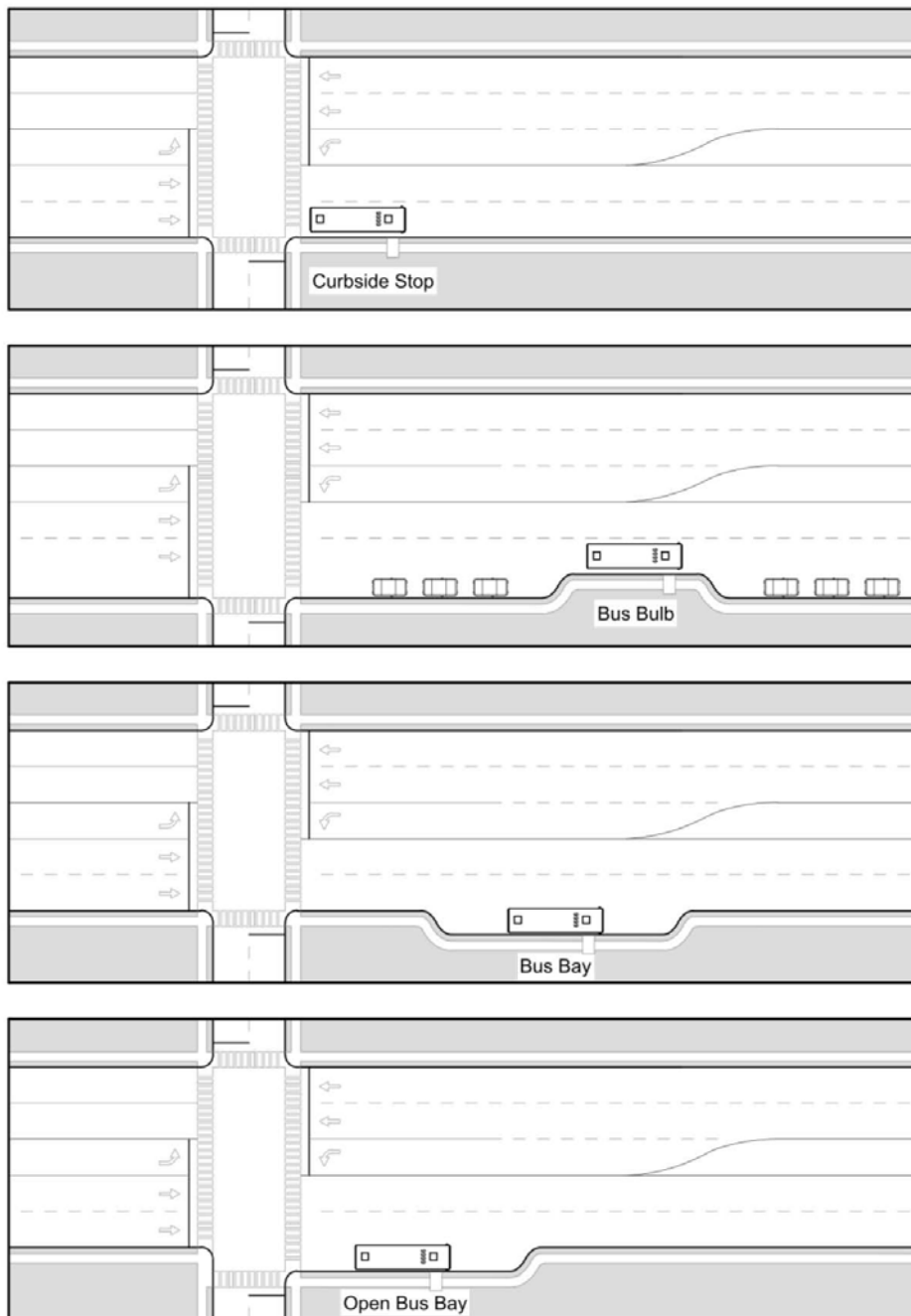

5.1 Lane Width

SANTA CRUZ METRO's buses operate most easily on lanes 12 feet or wider. However, this width is not always possible depending on the context of the roadway, and SANTA CRUZ METRO buses do operate on roadways with lane widths less than 12 feet due to limited right-of-way. On public roads, lane width

Attachment A

is decided by the appropriate municipality or jurisdiction. In private developments where SANTA CRUZ METRO buses will operate, SANTA CRUZ METRO recommends lane widths of 12 feet or more.

5.2 Roadway Grade

Changes in grade affect how well buses can easily negotiate changes in the roadway with adequate ground clearance for passenger safety and comfort. Changes in grade should be gradual (6% or less) to prevent buses from “bottoming out” or causing damage to the vehicle or roadway.

5.3 Roadway Pavement

For public roads, developers should follow appropriate state or municipal standards. However, if the roadway will be used by SANTA CRUZ METRO vehicles, the pavement should be constructed to handle vehicles with a bus axle weight of 27,760 lbs.

5.4 Concrete Bus Pads

For heavily-used bus stop areas, including bus bays and terminals, the rigid pavement design is strongly recommended. Due to the loads and shear forces applied to pavement surfaces during bus starting and stopping movements, this pavement surface has the best potential to retain its shape and resist breaking down over time.

The installation of concrete bus pads is up to the discretion of the appropriate municipality. The locations of recommended concrete pads will be influenced by bus frequency, speed, and existing pavement condition. Concrete bus pads should be installed to be the width of the curb lane and preferably extend the entire length of the appropriate bus stop zone. Thus, the concrete pads should be at least 125' long for near-side bus stops, 125' long for far-side bus stops, and 150' long for mid-block bus stops. In areas where more than one bus will arrive at the bus stop at one time, the length of the concrete pad should be extended by at least 50' for each additional expected bus (70' for each articulated bus). SANTA CRUZ METRO should be consulted to determine the number of buses expected to arrive or dwell at a bus stop simultaneously.

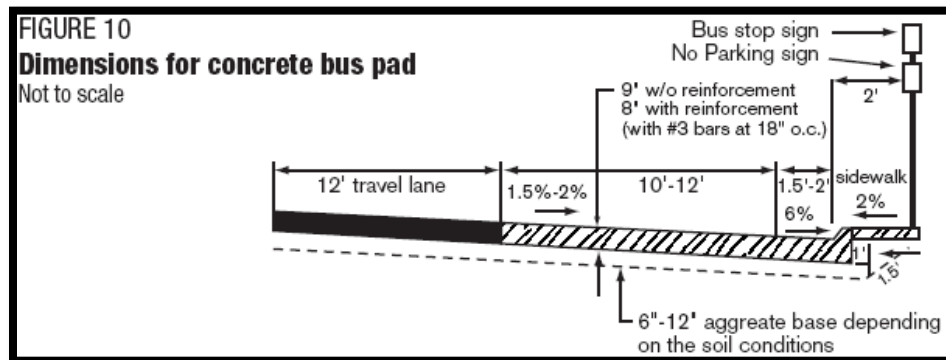

Attachment A

5.5 Typical Bus Turning Radii

The turning radius of SANTA CRUZ METRO's transit vehicles affects the design of intersections, roundabouts, and dedicated bus facilities such as turnarounds and park and rides. While the curb radius and other roadway design features of municipal streets is governed by the appropriate municipality, the typical turning radius of SANTA CRUZ METRO's vehicles should be considered, as it will affect the ability of SANTA CRUZ METRO to operate safely on roadways with minimal encroachment into other lanes of traffic. Private developments that are intended to receive bus service should design facilities that will accommodate smooth and easy turning movements by SANTA CRUZ METRO's vehicles. Such developments should be designed to accommodate a 30-foot inner turning radius and 60-foot outer turning radius.

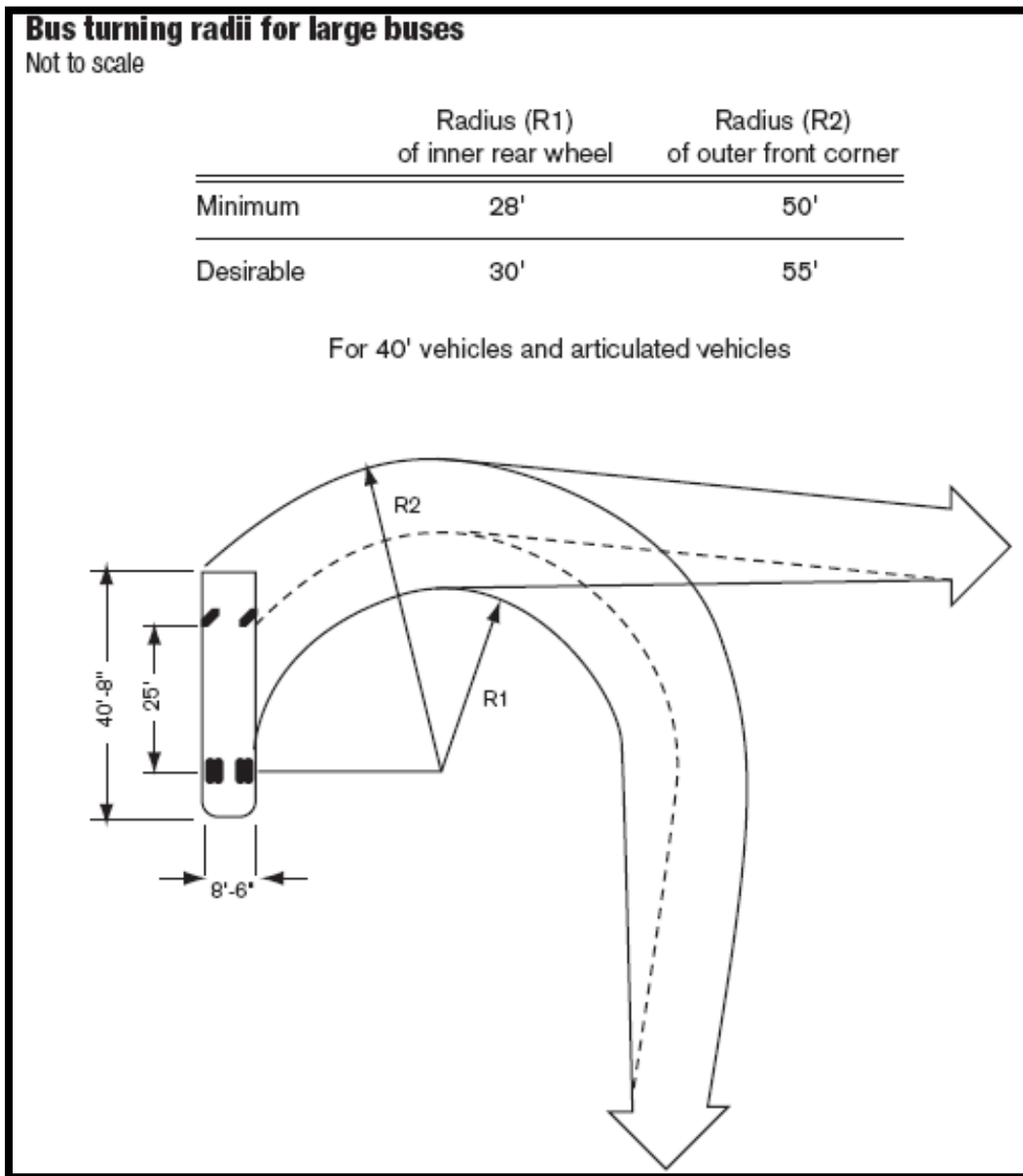

Attachment A

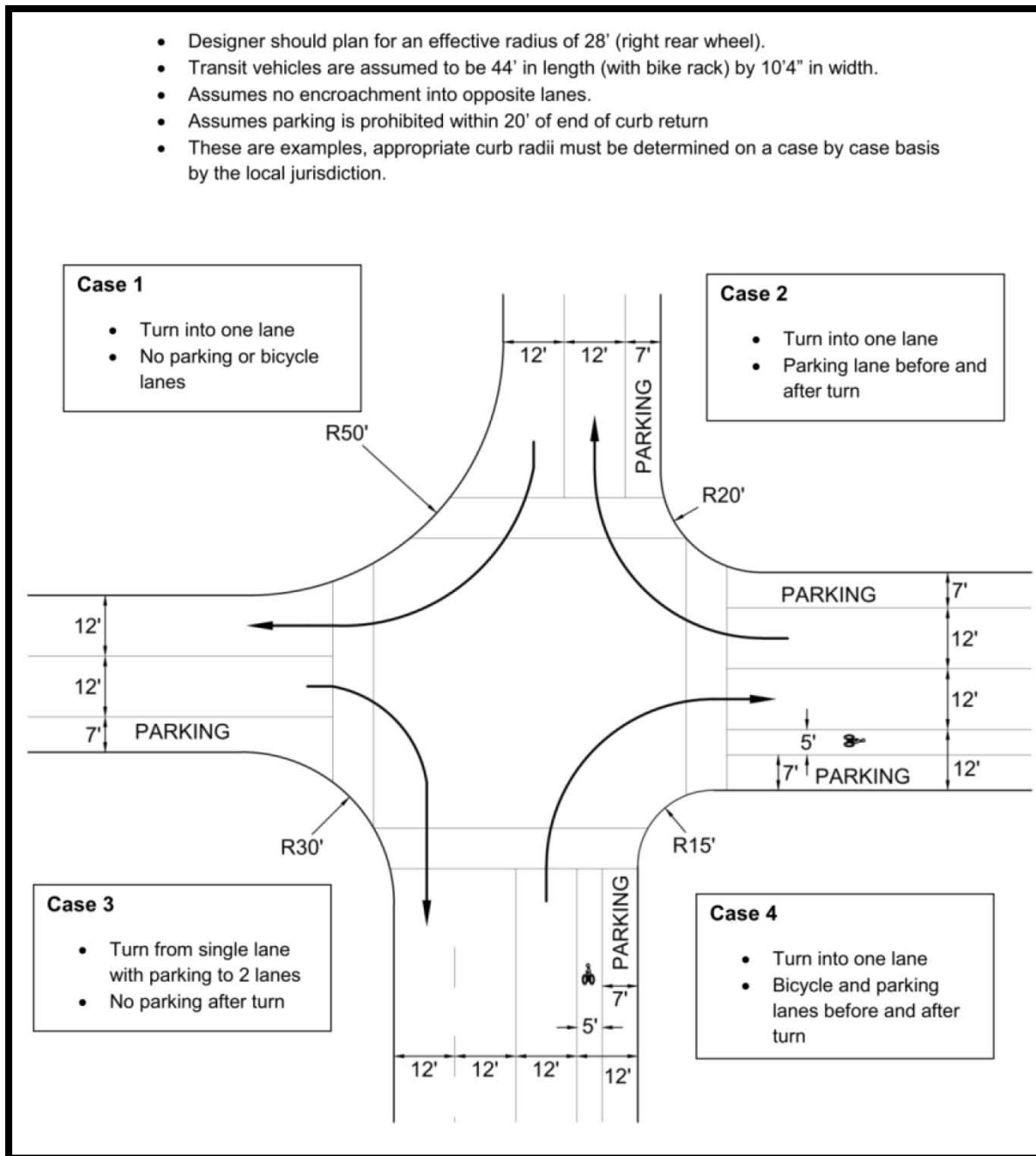

5.6 Street-side Dimensions

As described above, on-street bus stops are generally placed in one of three locations: near-side of the intersection, far-side of the intersection, or mid-block (between two intersections). On-street bus stops in the traffic lane are most appropriate on roadways with a speed limit of 35 mph or less. On higher-speed roads, bus bays may be preferred for the safety of pedestrians, bus operators, and drivers.

Attachment A

However, specific traffic conditions and existing right-of-way constraints will dictate what type of bus stop should be installed.

The figure below illustrates the three on-street bus stop locations along with measurements for parking setbacks. The measurements shown below illustrate the desired “clear zone” that should be provided at each bus stop location to provide for the safe movement of buses into and out of the parking or curb lane (20 feet should be added to each clear zone that will accommodate articulated buses). This clear zone is necessary when parking or other obstructions are located in the same lane in which the bus will be stopping. On roadways with only one thru-lane, bus stop zones should still be demarcated on either end by “no stopping” signs. SANTA CRUZ METRO realizes that these clear zones are not always possible given existing site conditions. However, these dimensions should be pursued to the extent possible, and SANTA CRUZ METRO should be contacted when designing bus stop zones so that operational data can be used to estimate necessary space requirements. Note that measurements given in the following illustrations only apply to bus stop zones where one bus at a time is expected in the zone. In other locations, where more than one bus may arrive and dwell at the same time, additional space is needed. In general, bus zones should increase by 50 feet for each additional standard bus and 70 feet for each additional articulated bus that is expected to use the zone simultaneously.

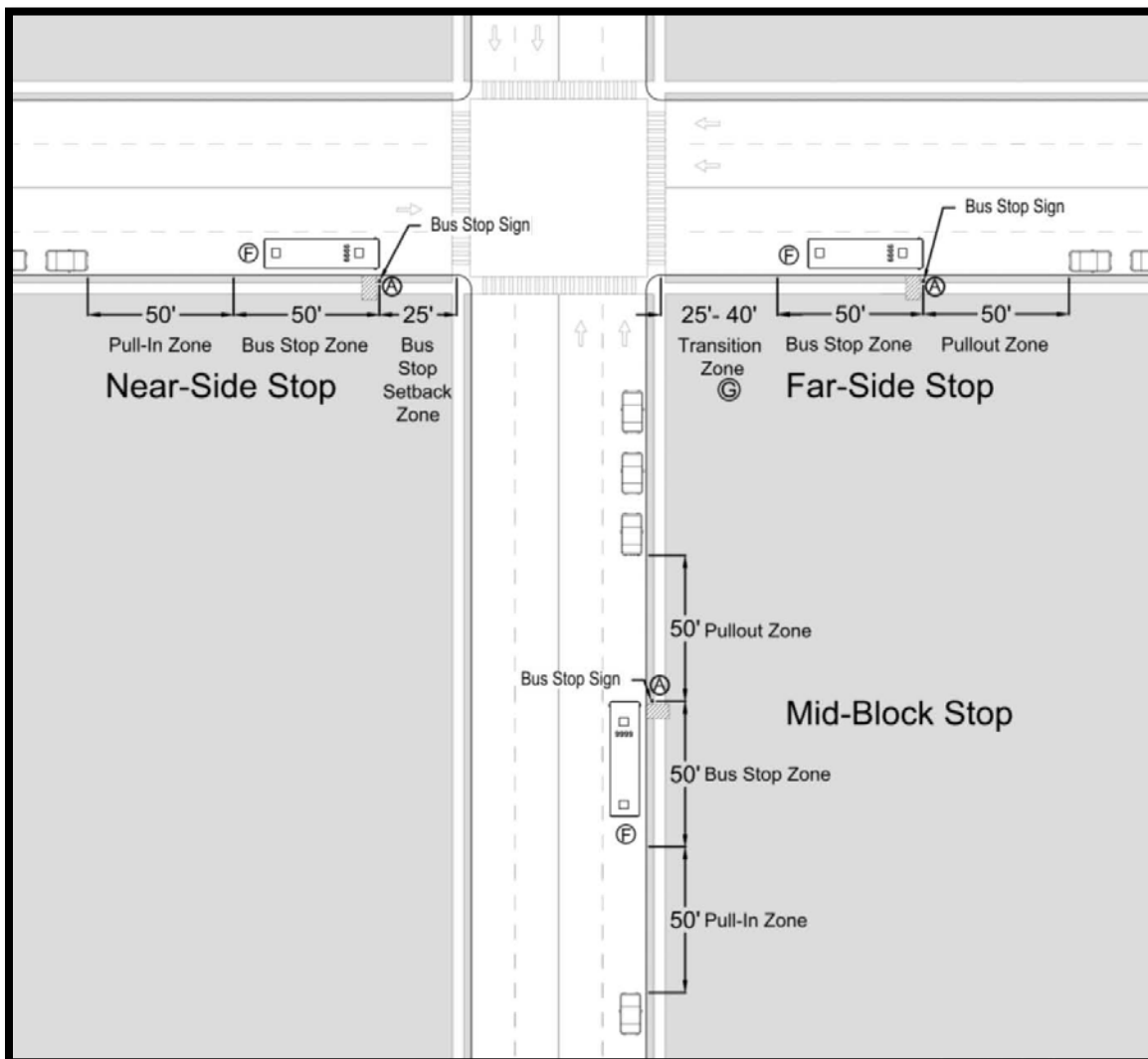

Attachment A

5.7 Bus Bays

Bus Bays are areas that are cut out of the roadway so that a bus can pull out of the traffic lane and passengers may board and alight safely. Sometimes these facilities require additional right-of-way acquisition and should always be coordinated with enhanced pedestrian facilities.

While bus bays are more commonly recommended for roadways with speed limits of 35 mph or above, bus bays can also be useful on lower-speed roads when they will be used as a layover location or otherwise provide a place for buses to dwell for a longer period of time. SANTA CRUZ METRO recommends two different approaches for constructing bus bays depending on what type of roadway they will be built on.

Mid Block Bus Bay:

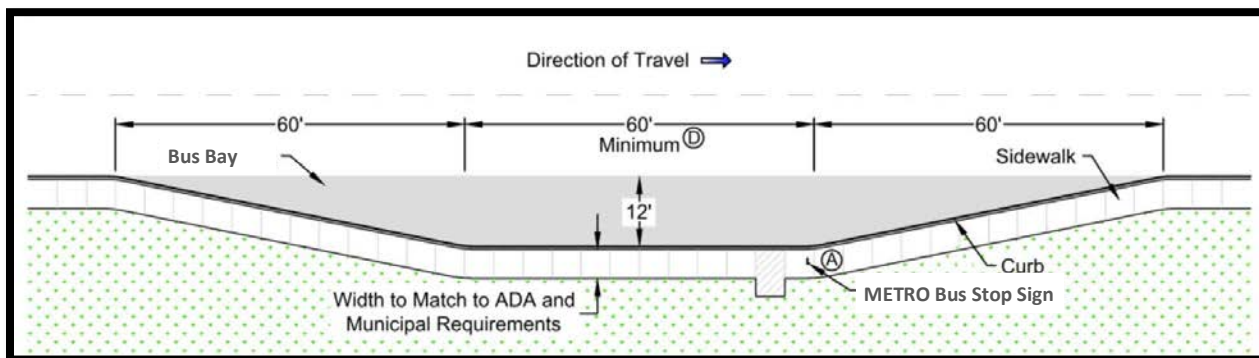

Far Side Bus Bay:

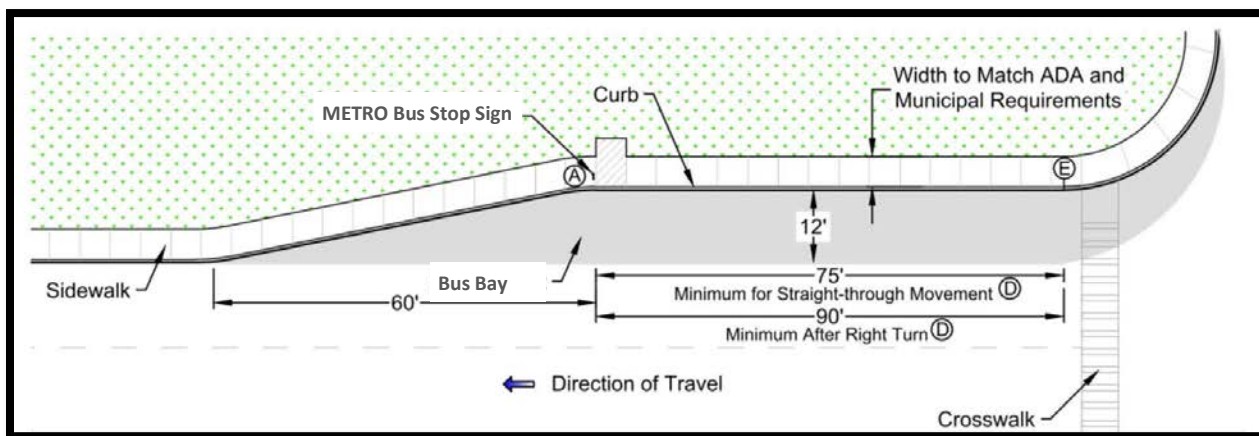

(Courtesy of COTA)

Attachment A

The type of bus bay design, described in the Transit Cooperative Research Program Report 19, is well suited for higher-speed, higher-volume roadways where long entrance and exit tapers should be provided so that the bus can achieve both deceleration and acceleration outside of the through-traffic lane. These bus bays are designed to provide minimal interruption to through-traffic on a busy road, and the dimensions vary with the speed limit of the roadway.

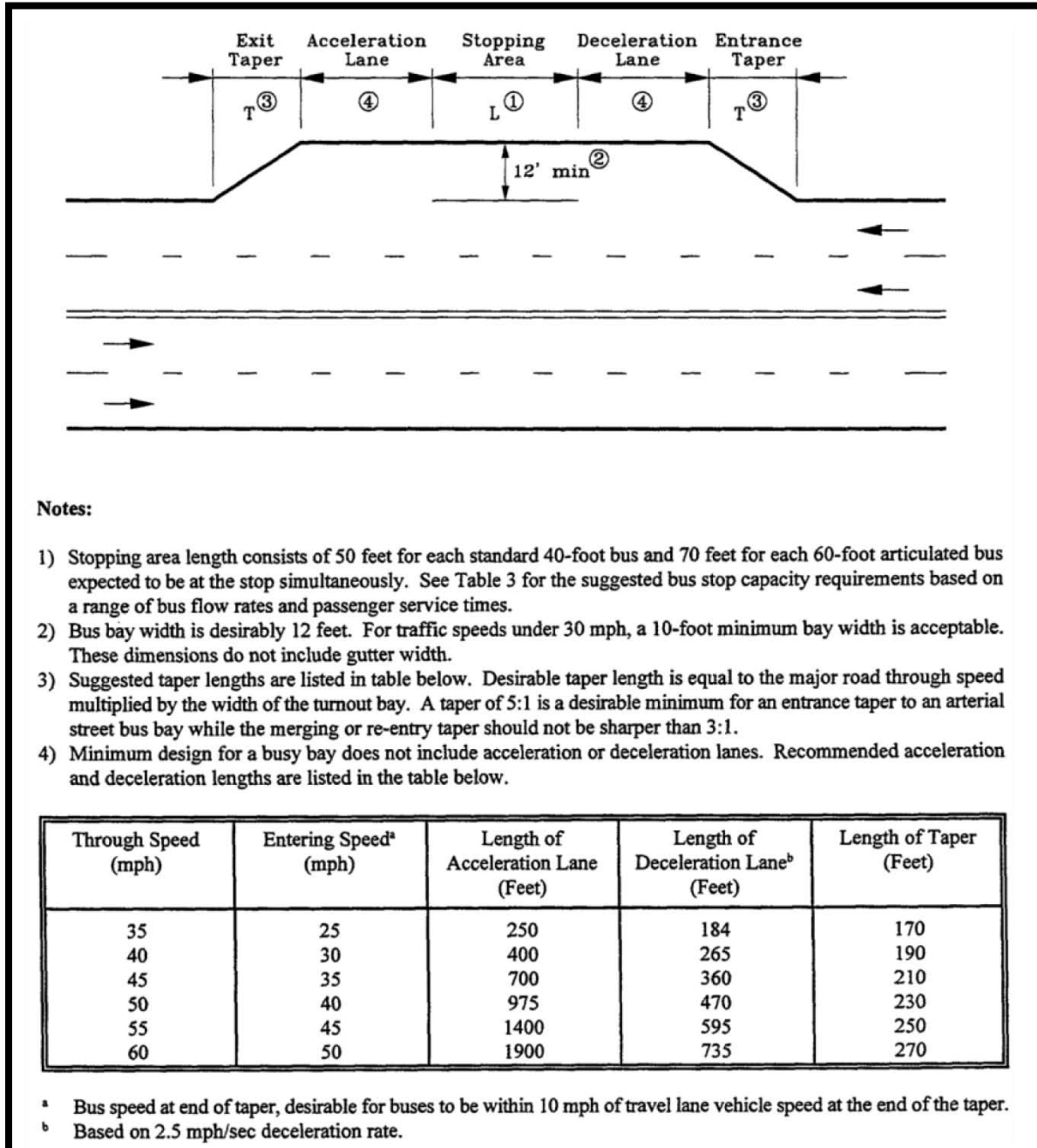

(Courtesy of TCRP)

This page is intentionally left blank

Attachment A

6. Transit-Friendly Design & Pedestrian Access

The land use and transportation system patterns of a city or neighborhood strongly affect the efficiency and viability of public transportation. In general, the two main factors that affect the level of service of public transportation to an area and its population are pedestrian accessibility and development density. Pedestrian accessibility is important because every transit rider is also a pedestrian. Most trips to and from the transit stop are made by foot, and thus sidewalks and other pedestrian amenities are essential to completing trips by transit. This is especially true for certain segments of the population, such as the elderly and persons with disabilities, who rely on quality pedestrian infrastructure for mobility. The quality of pedestrian access is driven by two factors: the directness and continuity of the sidewalk network and the proximity of the buildings to that sidewalk network.

Development density is also important for the success of public transportation because public transportation is, by definition, designed to transport large numbers of people from one general location to another. To be cost-efficient and provide an adequate level of service, transit must be able to reach relatively large concentrations of people. This does not mean that very high density development (such as downtown San Francisco) is required for successful public transportation. Medium-density residential developments and commercial developments with strong activity centers are sufficient to support convenient transit service with high ridership potential. Additionally, lack of density can be offset in some instances with the use of park & ride lots and other unique services tailored for specific applications.

In a more general sense, transit-friendly design can be accomplished by following “complete streets” principles when designing internal and external transportation systems. The Monterey Bay Area Complete Streets Guidebook is an excellent resource for learning about and implementing complete streets principles. The toolkit can be found online at: <http://sccrtc.org/wp-content/uploads/2013/08/final-2013-complete-streets-guidebook.pdf>

7. Appendix

Contents:

- A-1: Development Review Checklist for Consideration of Transit
- B-1: Bus Stop Modification Request
- B-2: Assessment of Bus Stop Request
- C-1: Typical Bus Stop Layout with Bench
- C-2: Typical Bus Stop Layout with Bench – Narrow Sidewalk
- C-3: Typical Bus Stop Layout with Simme Seat
- C-4: Typical Bus Stop Layout with Simme Seat – Narrow Sidewalk
- C-5: Typical Bus Stop Layout with Shelter
- C-6: Typical Bus Stop Layout with Shelter – Narrow Sidewalk
- C-7: Typical Bus Stop Layout with Shelter – Bus Bay
- C-8: Typical Bus Stop Layout with Shelter – Bus Bay and Bicycle Lane
- D-1: ADA Standards for Transportation Facilities – Excerpts Related to Transit

Attachment A



Appendix A-1

Development Review Checklist for Consideration of Transit

SANTA CRUZ METRO will review development and roadway improvement plans to identify transit needs and opportunities and provide feedback on the designs. Ongoing communication between SANTA CRUZ METRO, the appropriate city and county, and the developer may be necessary in order to solidify details of:

- Transit routes and modifications
- Bus stop placement
- Bus stop design, including ADA-compliance and adherence to federal regulations
- Temporary reroutes and bus stops

Below is a checklist to be completed to ensure transit considerations for developments and roadway improvements:

Transit Circulation and Bus Stop Placement			
	Yes	No	N/A
Has SANTA CRUZ METRO been contacted to verify that transit service currently exists adjacent to a proposed development, or may be feasible in the future?			
Are large developments designed to permit safe routing of buses through the development? Note: deviating from primary routing to service a development adds travel time, and will be considered only if SANTA CRUZ METRO deems it appropriate			
For all roadways and driveways, do all grades conform to SANTA CRUZ METRO's Bus Stop Guide?			
For all roadways and driveways that will accommodate buses, are lane widths 10-12 ft?			
For all roadways, driveways, and bus stops that will accommodate buses, have pavement cross-sections been designed to conform to SANTA CRUZ METRO's Bus Stop Guide (ideally including concrete bus pads)?			
Will structures and landscaping permit sufficient vertical and horizontal clearances for buses?			
Are proposed bus stops connected to primary destinations with an ADA-compliant pedestrian access path free of obstacles?			
Bus Stop Amenities and Designs			
Has SANTA CRUZ METRO been contacted to explore whether a new or relocated bus stop can be provided on or adjacent to the proposed project?			
If a bus stop currently exists on or adjacent to the proposed project, has SANTA CRUZ METRO been contacted to explore specific bus stop improvements and/or changes to the existing bus stop amenities?			
If the project requires bus stop improvements or amenity changes, have the proposed elements been designed to be consistent with SANTA CRUZ METRO's Bus Stop Guide?			
If new or relocated transit stops are proposed or required, are they designed to be located in a safe, visible, and well-lit location, in reasonable proximity to primary destinations, as well as consideration for bus stops service the opposite direction?			



Bus Stop Modification Request

-Request to Add, Remove, Modify, or Relocate a Santa Cruz METRO Bus Stop-

Please fill out form completely and include accurate contact information so that we may respond to your request

Requestor

Name:

Company/Affiliation (if applicable):

Address:

Phone Number or Email:

Date of Request:

Request to: Relocate Modify
(circle one or more)

If modify: Add Remove

- Shelter
- Simme Seat
- Bench
- Trash Receptacle

(circle one or more)

What bus route(s) serves this stop?

Reason for Request (Required):

Description of Bus Stop

Bus Stop Number (found posted on the bus stop signage):

Nearest Intersection:

Direction of travel: Northbound Southbound Eastbound Westbound
(circle one)

Thank you for your input. Your request will be reviewed by Santa Cruz METRO's Planning Department using established criteria to make a determination. Bus stop changes are affected by several factors, including: ridership, bus stop spacing, land use, population density, existing roadway and pedestrian conditions, and important destinations. After a comprehensive review, the Planning Department will recommend an action to Santa Cruz METRO's Maintenance Manager for final ruling.



Assessment of Bus Stop Request

(Internal Use Only - Planning Staff)

Requestor:

Name:
Company/Affiliation (if applicable):
Address:
Phone Number or Email:
Date of Request:
Request to: Add Remove Relocate Modify
Modify: install shelter install bench install Simme Seat install trash receptacle

Assessment:

Description of Current Bus Stop/Location (if applicable)

Bus Stop ID:
Nearest Intersection:
Direction of Travel: Northbound Southbound Eastbound Westbound
Placement: Nearside Farside Midblock
Routes Served:
Number of Departures:

Description of Requested Bus Stop Location (if applicable)

Nearest Intersection:
Direction of Travel: Northbound Southbound Eastbound Westbound
Placemen: Nearside Farside Midblock
Routes Served:
Number of Departures:

Location Land Use/Density:

Surrounding Land Use: Residential Office Education Retail Park Mixed
Central Business District Other:
Density:
Nearby sensitive land uses:

Nearest Active SCMTD Bus Stop:

Prior Stop:
Next Stop:

Existing Road Conditions:

Street Type: Local Collector Arterial
Number of Lanes:
Speed Limit:
Nearby major destinations:
Right of Way/Jurisdictional Concerns:



Attachment A

Existing Pedestrian/Accessibility Conditions:

Sidewalks to/from stop location:	Yes	No	Partial
Curb ramps at intersections:	Yes	No	Partial
Crosswalk or traffic controlled intersection:	Yes	No	

Ridership and Transfers:

Average Weekday Boardings:
Average Weekend Boardings:
Can transfers occur at this location: Yes No

Existing Amenities (if applicable):

Shelter	ADA Landing Pad	Trash Receptacle	Lighting	Bike Rack
Simme Seat	Bench	Other:		

Bus Shelter Request:

Does the location meet average boarding requirements?	Yes	No
Do existing conditions permit shelter installation?	Yes	No
Is there an existing shelter at a nearby stop?	Yes	No
Is surrounding land use, density, and/or major destinations consistent with shelter requirements?	Yes	No

Bench / Simme Seat Request:

Does the location meet average boarding requirements?	Yes	No
Do existing conditions permit bench/Simme Seat installation?	Yes	No
Is there an existing bench/Simme Seat at a nearby stop?	Yes	No

Trash Receptacle Request:

Is the stop at a driver recovery location and/or a bus shelter?	Yes	No
Does the stop meet average boarding requirements?	Yes	No
Is the stop near a restaurant/food establishment?	Yes	No
How many requests have been received at this stop:		

Assessment: **Request Approved** **Request Denied**

Reasoning for Assessment:

Assessor:

Date of Assessment:

Maintenance Manager Ruling:

Follow Up Action:

Attachment A Typical Bus Stop Layout With Bench

Appendix C-1

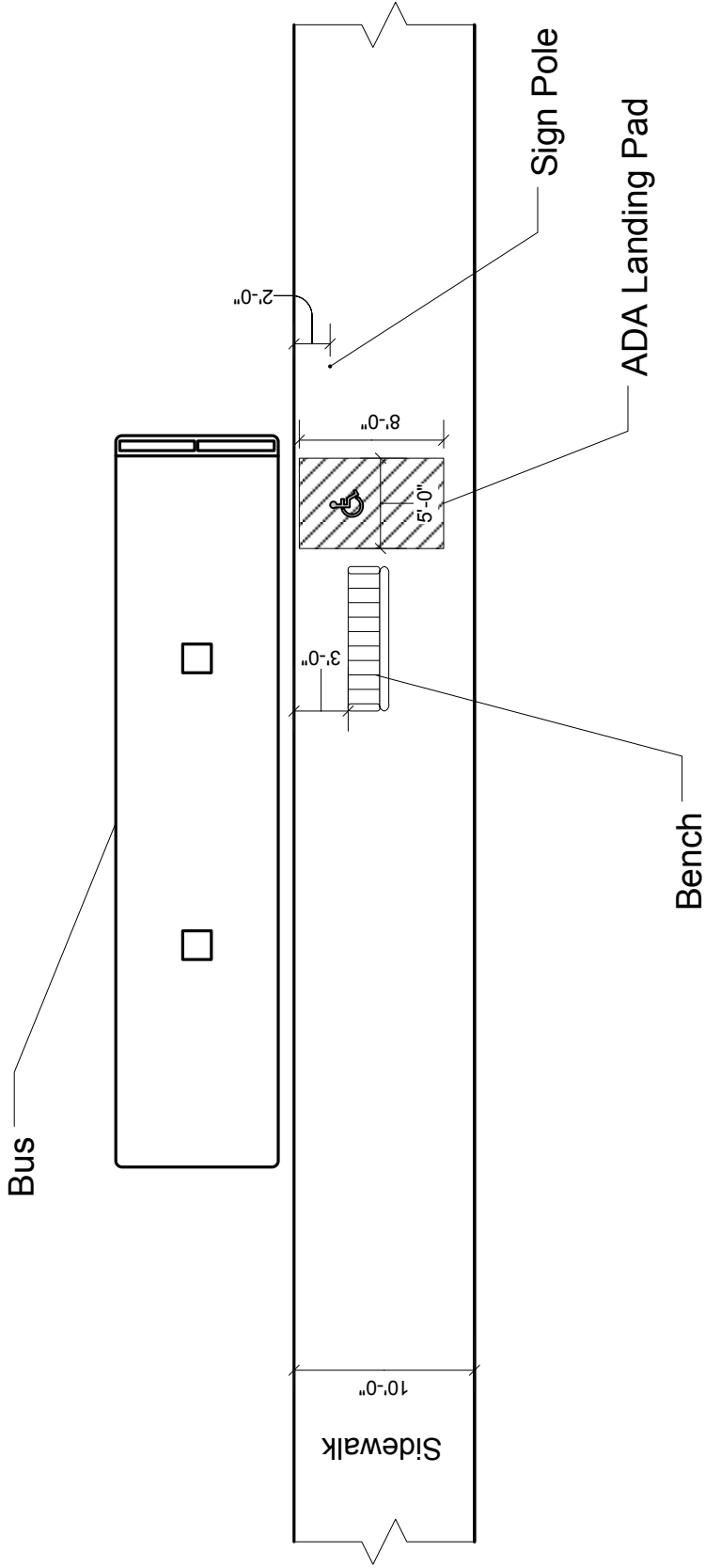

12A.42

Scale: 1/120 : 1



Typical Bus Stop Layout With Bench – Narrow Sidewalk

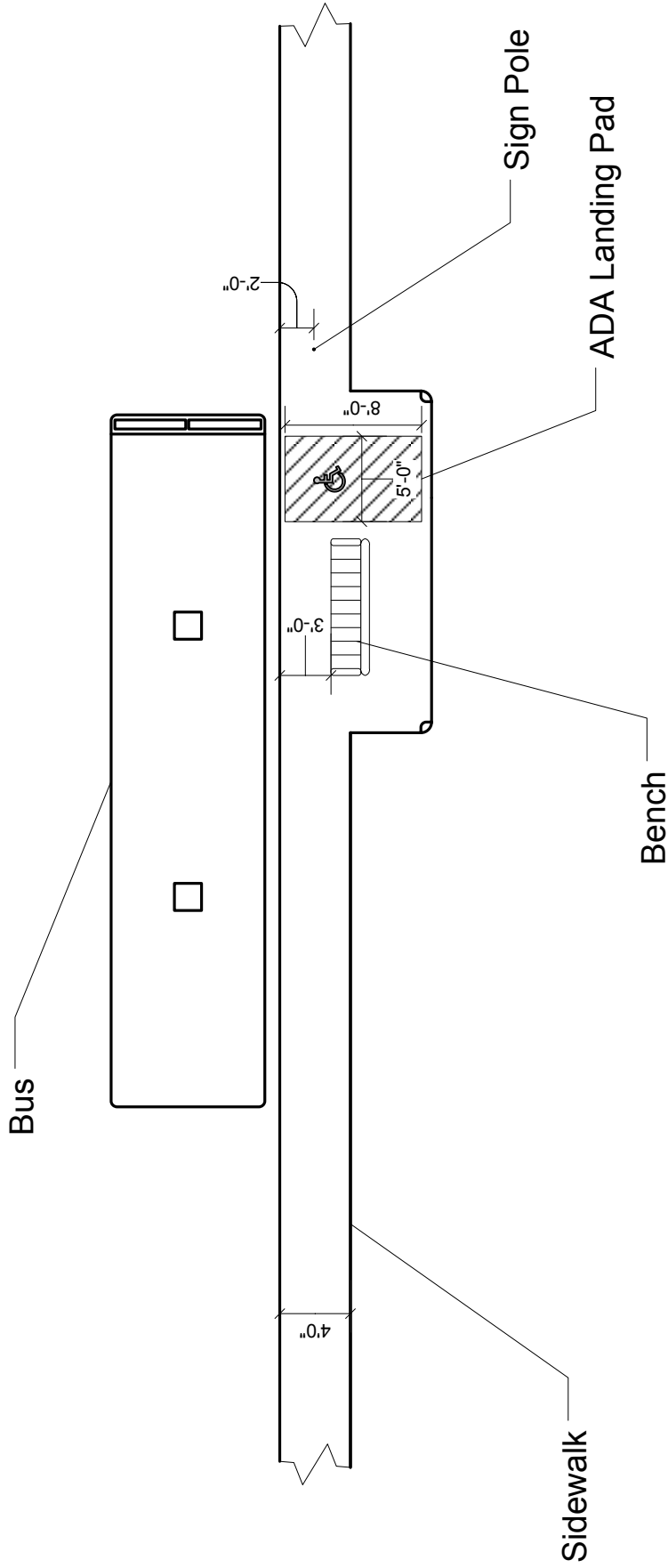

Scale: 1/120 : 1



Attachment A Typical Bus Stop Layout With Simme Seat

Appendix C-3

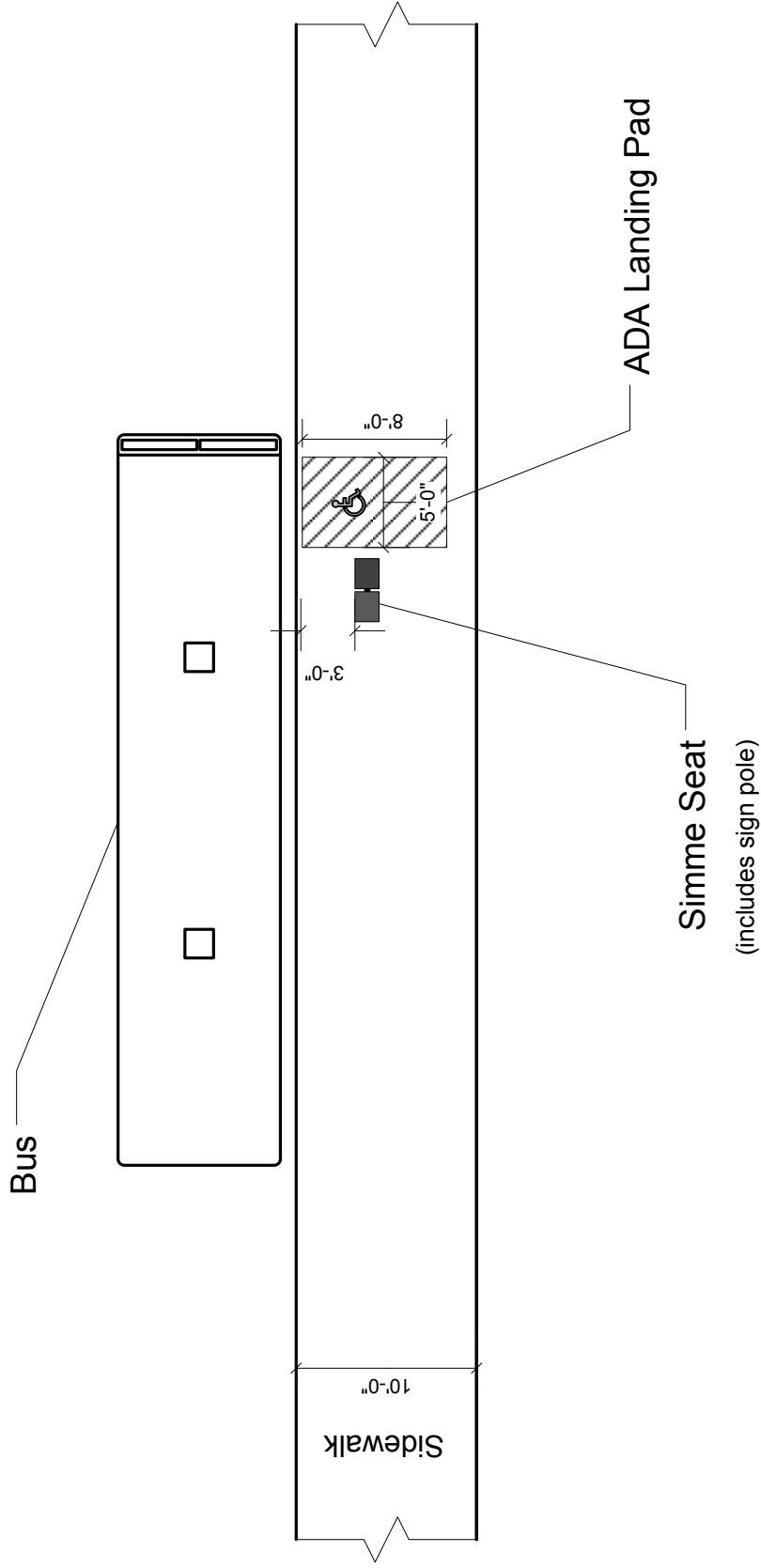

12A.44

Scale: 1/120 : 1



Typical Bus Stop Layout Attachment A With Simme Seat – Narrow Sidewalk

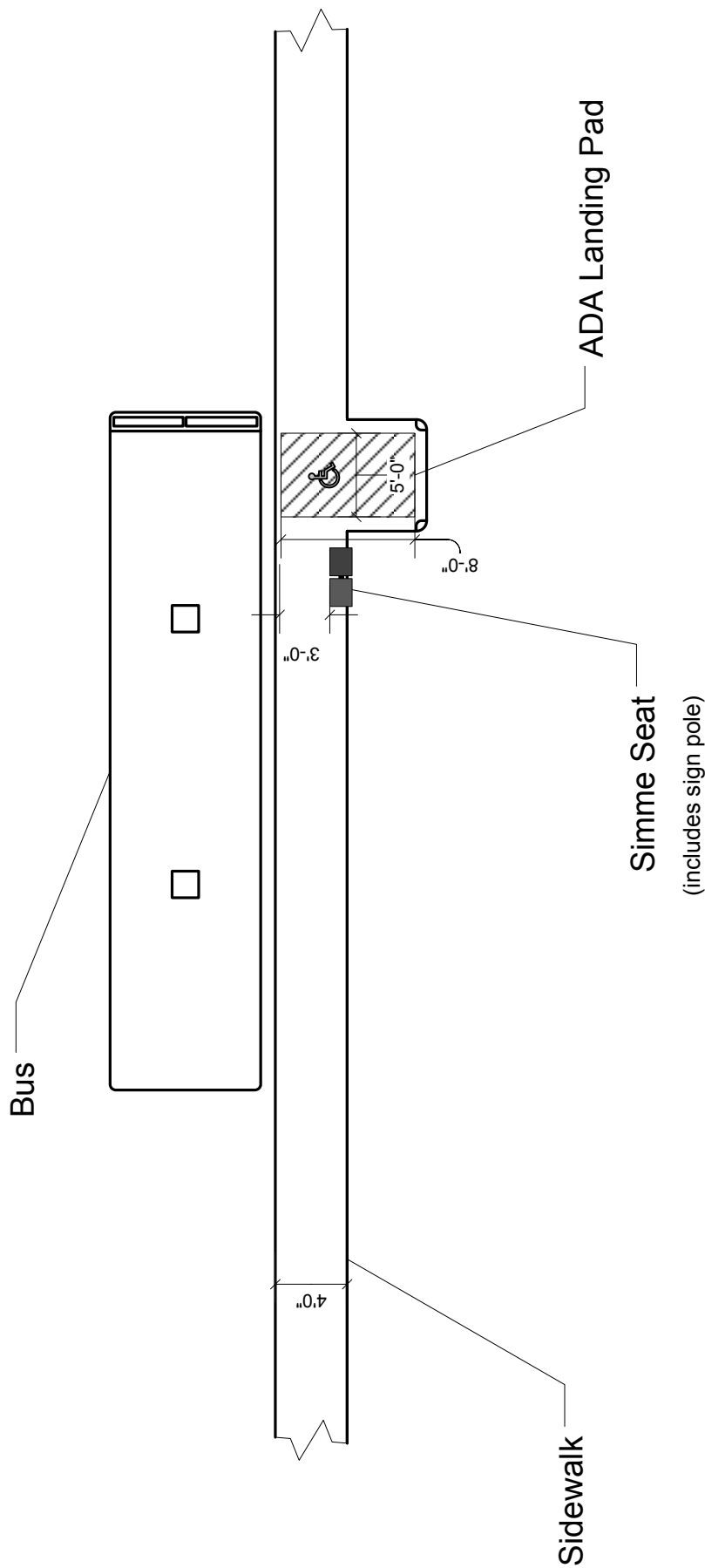

12A.45

Scale: 1/120 : 1



Typical Bus Stop Layout With Shelter

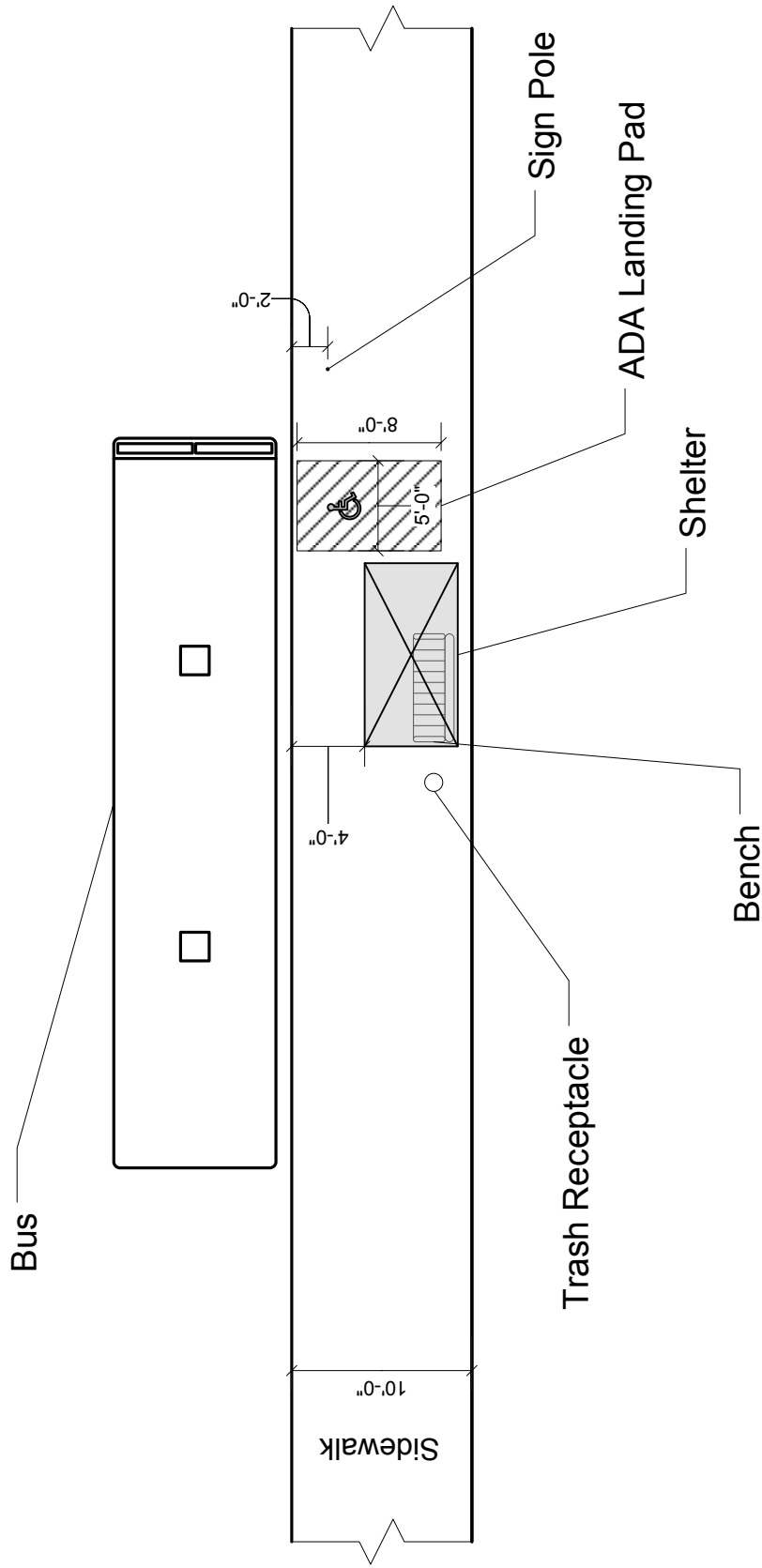

Typical Bus Stop Layout Attachment A With Shelter – Narrow Sidewalk

Appendix C-6

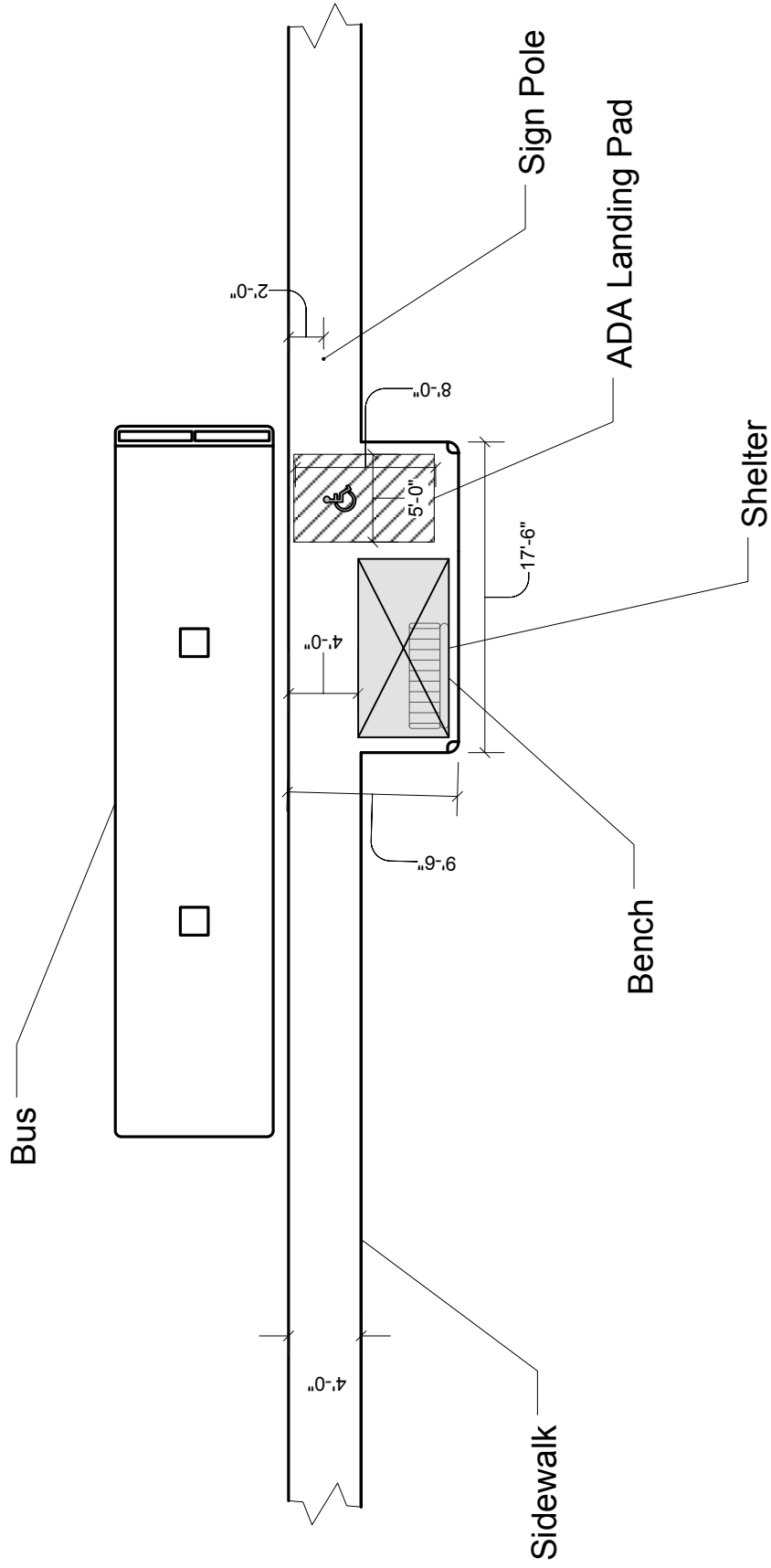

12A.47

Scale: 1/120 : 1



Typical Bus Stop Layout With Shelter – Bus Bay

Appendix C-7

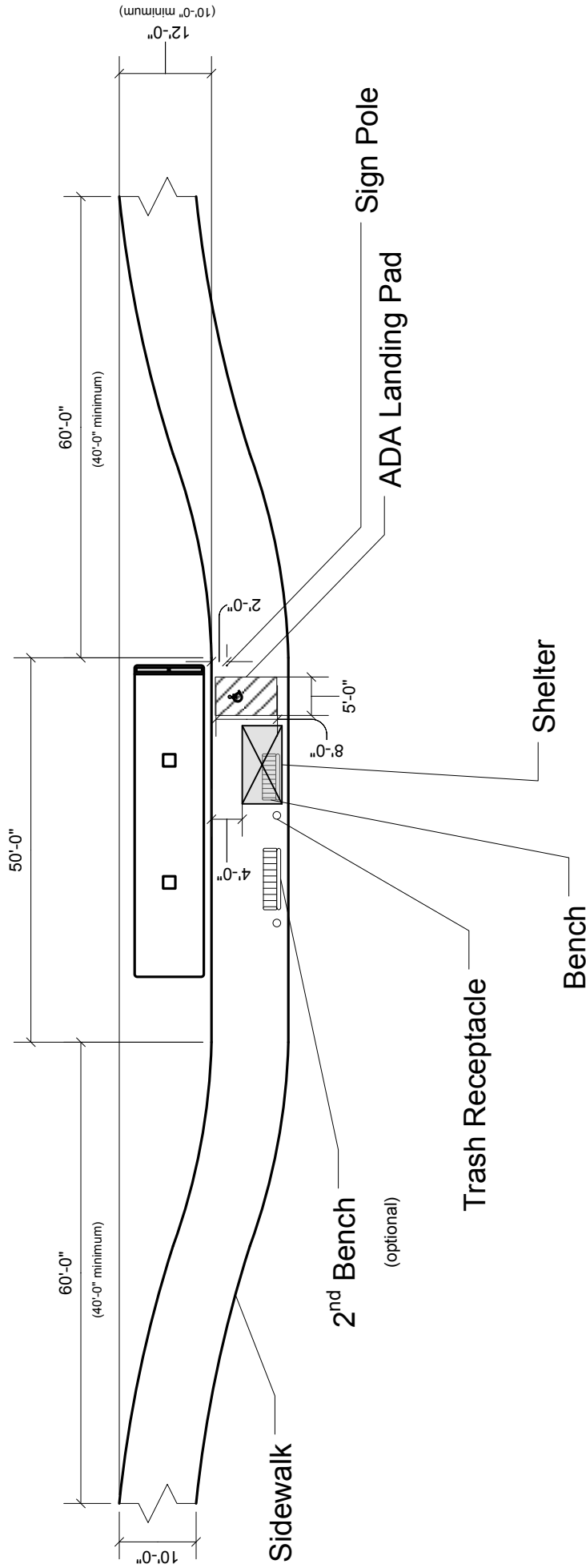

Typical Bus Stop Layout Attachment A With Shelter – Bus Bay and Bicycle Lane

Appendix C-8

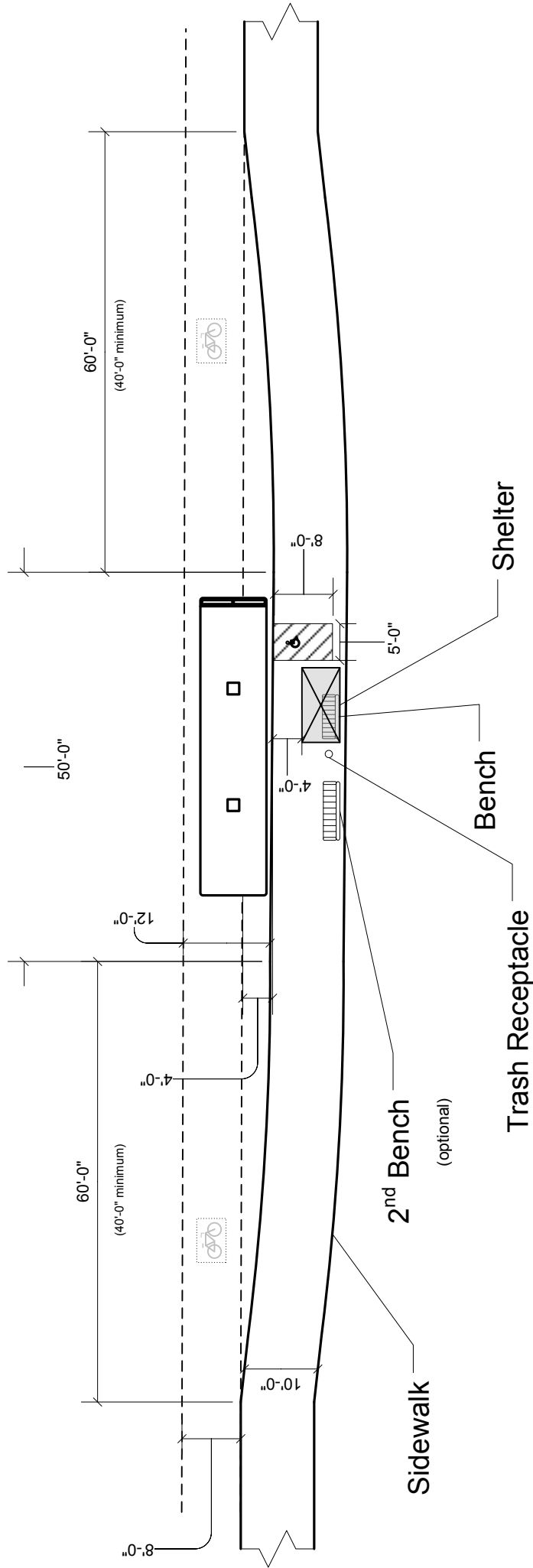

12A.49

Scale: 1/240 : 1





ADA Standards for Transportation Facilities – Excerpts Related to Transit

-Source: United States Access Board 2010-

402 Accessible Routes

402.1 General. Accessible routes shall comply with 402.

402.2 Components. Accessible routes shall consist of one or more of the following components: walking surfaces with a running slope not steeper than 1:20, doorways, ramps, curb ramps excluding the flared sides, elevators, and platform lifts. All components of an accessible route shall comply with the applicable requirements of Chapter 4.

Advisory 402.2 Components. Walking surfaces must have running slopes not steeper than 1:20, see 403.3. Other components of accessible routes, such as ramps (405) and curb ramps (406), are permitted to be more steeply sloped.

403 Walking Surfaces

403.1 General. Walking surfaces that are a part of an accessible route shall comply with 403.

403.2 Floor or Ground Surface. Floor or ground surfaces shall comply with 302.

403.3 Slope. The running slope of walking surfaces shall not be steeper than 1:20. The cross slope of walking surfaces shall not be steeper than 1:48.

403.4 Changes in Level. Changes in level shall comply with 303.

403.5 Clearances. Walking surfaces shall provide clearances complying with 403.5.

****EXCEPTION:** Within employee work areas, clearances on common use circulation paths shall be permitted to be decreased by work area equipment provided that the decrease is essential to the function of the work being performed.

403.5.1 Clear Width. Except as provided in 403.5.2 and 403.5.3, the clear width of walking surfaces shall be 36 inches (915 mm) minimum.

****EXCEPTION:** The clear width shall be permitted to be reduced to 32 inches (815 mm) minimum for a length of 24 inches (610 mm) maximum provided that reduced width segments are separated by segments that are 48 inches (1220 mm) long minimum and 36 inches (915 mm) wide minimum.

Attachment A



Appendix D-1

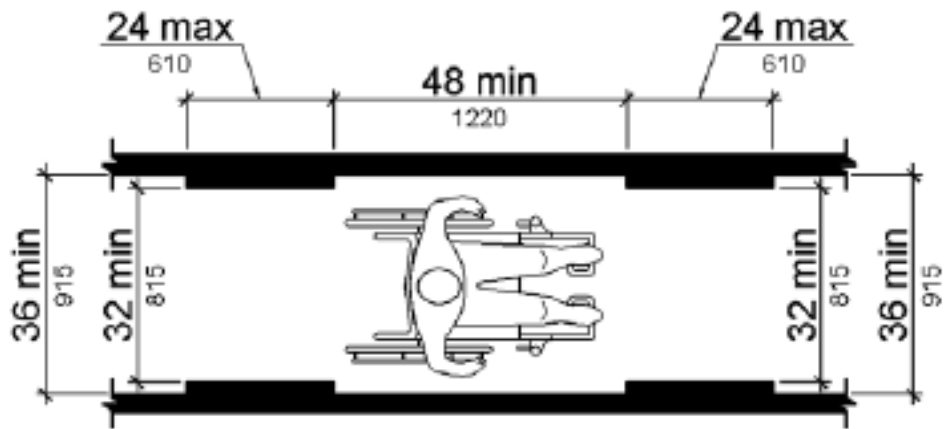

403.5.2 Clear Width at Turn. Where the accessible route makes a 180 degree turn around an element which is less than 48 inches (1220 mm) wide, clear width shall be 42 inches (1065 mm) minimum approaching the turn, 48 inches (1220 mm) minimum at the turn and 42 inches (1065 mm) minimum leaving the turn.

**EXCEPTION: Where the clear width at the turn is 60 inches (1525 mm) minimum compliance with 403.5.2 shall not be required.

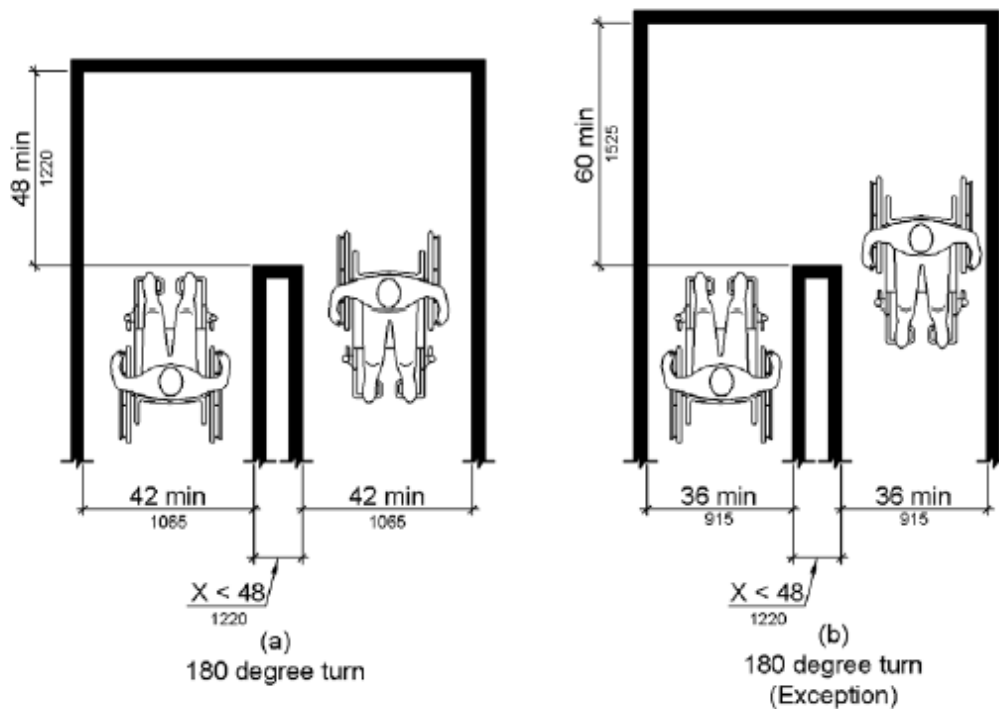

Attachment A



Appendix D-1

403.5.3 Passing Spaces. An accessible route with a clear width less than 60 inches (1525 mm) shall provide passing spaces at intervals of 200 feet (61 m) maximum. Passing spaces shall be either: a space 60 inches (1525 mm) minimum by 60 inches (1525 mm) minimum; or, an intersection of two walking surfaces providing a T-shaped space complying with 304.3.2 where the base and arms of the T-shaped space extend 48 inches (1220 mm) minimum beyond the intersection.

403.6 Handrails. Where handrails are provided along walking surfaces with running slopes not steeper than 1:20 they shall comply with 505.

Advisory 403.6 Handrails. *Handrails provided in elevator cabs and platform lifts are not required to comply with the requirements for handrails on walking surfaces.*

810 Transportation Facilities

810.1 General. Transportation facilities shall comply with 810.

810.2 Bus Boarding and Alighting Areas. Bus boarding and alighting areas shall comply with 810.2.

Advisory 810.2 Bus Boarding and Alighting Areas. *At bus stops where a shelter is provided, the bus stop pad can be located either within or outside of the shelter.*

810.2.1 Surface. Bus stop boarding and alighting areas shall have a firm, stable surface.

810.2.2 Dimensions. Bus boarding and alighting areas shall provide a clear length of 96 inches (2440 mm), measured perpendicular to the curb or vehicle roadway edge, and a clear width of 60 inches (1525 mm), measured parallel to the vehicle roadway.

Public entities shall ensure that the construction of bus boarding and alighting areas comply with 810.2.2, to the extent the construction specifications are within their control.

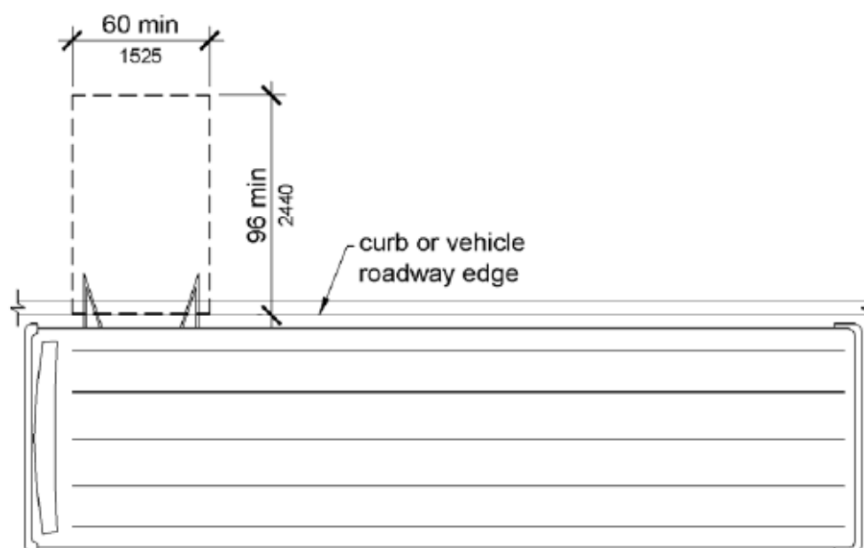

Attachment A



Appendix D-1

810.2.3 Connection. Bus stop boarding and alighting areas shall be connected to streets, sidewalks, or pedestrian paths by an accessible route complying with 402.

810.2.4 Slope. Parallel to the roadway, the slope of the bus stop boarding and alighting area shall be the same as the roadway, to the maximum extent practicable. Perpendicular to the roadway, the slope of the bus stop boarding and alighting area shall not be steeper than 1:48.

810.3 Bus Shelters. Bus shelters shall provide a minimum clear floor or ground space complying with 305 entirely within the shelter. Bus shelters shall be connected by an accessible route complying with 402 to a boarding and alighting area complying with 810.2.

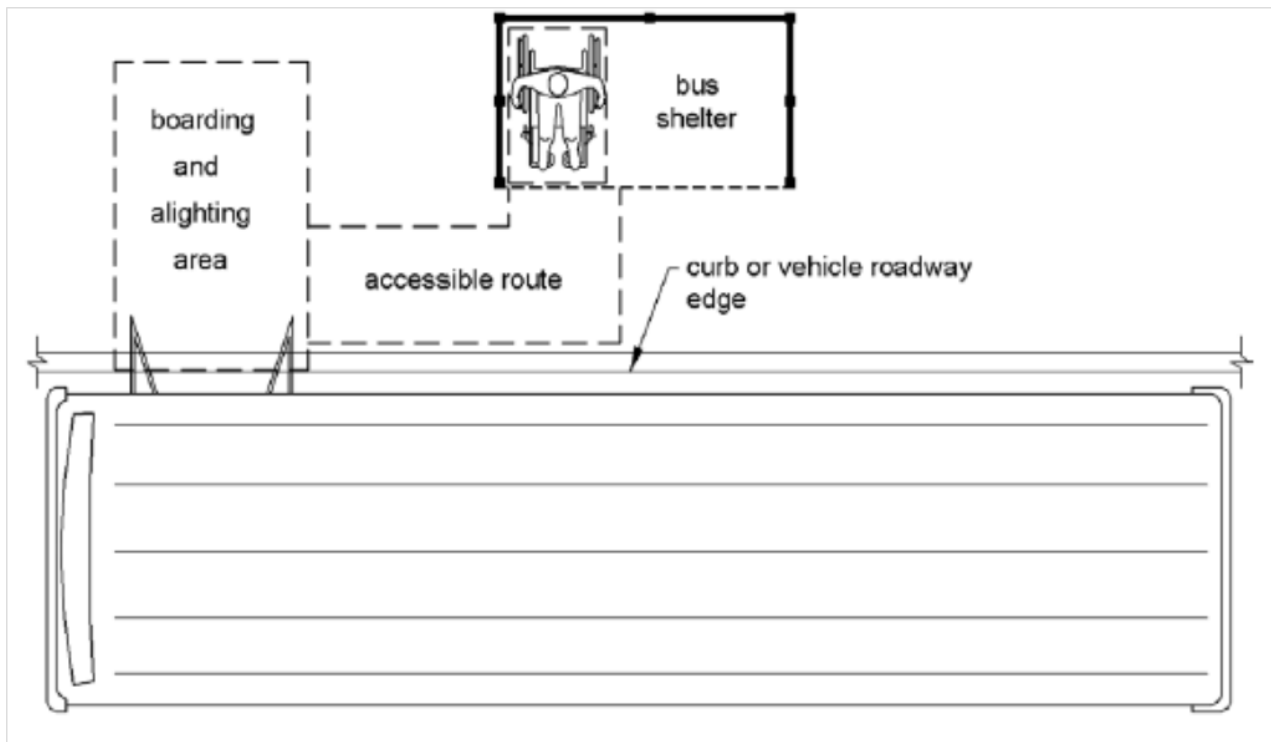

810.4 Bus Signs. Bus route identification signs shall comply with 703.5.1 through 703.5.4, and 703.5.7 and 703.5.8. In addition, to the maximum extent practicable, bus route identification signs shall comply with 703.5.5.

**EXCEPTION: Bus schedules, timetables and maps that are posted at the bus stop or bus bay shall not be required to comply.

- THIS PAGE INTENTIONALLY LEFT BLANK -



DATE: August 28, 2015
TO: Board of Directors
FROM: Isaac Holly, I.T. Manager
SUBJECT: INFORMATION TECHNOLOGY (IT) STAFF RESTRUCTURE

I. RECOMMENDED ACTION

That the Board of Directors authorize the CEO to put the Assistant Information Technology (IT) Manager position into an unfunded status, reallocate said funds to a Database Administrator position and other line items within the IT department operating budget.

II. SUMMARY

- The METRO Board authorized the Database Administrator position on November 14, 2014.
- In the FY16 & FY17 budget, the Database Administrator was unfunded due to budgetary concerns.
- On July 14, 2015, the Assistant IT Manager was promoted to IT Manager.
- The vacancy of the funded Assistant IT Manager provides the opportunity to fund the Database Administrator and other line items within the FY16 & FY17 IT operating budget.

III. DISCUSSION/BACKGROUND

On November 14, 2014 the METRO Board authorized the Database Administrator position and METRO began preparation to recruit for this position. In the FY16 & FY17 Board approved budget, the decision was made to leave a number of approved positions, including the Database Administrator, unfunded due to budgetary concerns.

During this time, the IT Manager position had been funded but left vacant while the Assistant IT Manager was functioning in an “Acting” capacity and the recruitment process for the IT Manager position was underway.

On July 14, 2015, the Assistant IT Manager was promoted to IT Manager thus leaving a funded vacancy within the IT Department. This vacancy presents METRO with the opportunity to restructure the IT department and to fund the Database Administrator position along with other line items within the IT department operating budget.

The Database Administrator role is vital in addressing the growing needs for software upgrades, integration, website development, data warehousing, reporting, and succession planning. METRO has a growing number of data systems and processes that require the specific skill set of a Database Administrator to perform programming, maintenance and repair operations on these systems. At present, the METRO IT Department has a Senior Database Administrator on staff and the database related workload has increased significantly.

Furthermore, in the event of the absence of the Senior Database Administrator, the ability of the remaining METRO IT staff to respond to and effectively resolve specific issues that require the specialized knowledge and skill set of a Database Administrator would be extremely difficult to address in an effective and timely manner. For this reason alone it is critical that a Database Administrator be on staff for business continuity.

The following are examples of METRO projects and initiatives that are driving the need for a Database Administrator in addition to the existing Senior Database Administrator:

- Developing an Enterprise Resource Planning (ERP) solution that encompasses data from all METRO departments for reporting and metrics such as Key Performance Indicators (KPIs).
- Procurement, integration and maintenance of new HR, Finance and Purchasing systems.
- Knowledge transfer of existing METRO data systems and processes from the Senior Database Administrator to the Database Administrator for redundancy and succession planning.

Staff recommends the following:

- Place the Assistant IT Manager position into unfunded status for FY16 & FY17.
- Reallocate funds to fill the Database Administrator position in FY16 & FY17.
- Distribute residual funds into the FY16 & FY17 IT department operating budget.

IV. FINANCIAL CONSIDERATIONS/IMPACT

The total Labor and Fringe Benefits cost for the Assistant IT Manager currently funded in FY16 is \$179,000.

The total Labor and Fringe Benefits cost for the Database Administrator, if funded in FY16 would be approximately \$140,000.

Since the total Labor and Fringe Benefits cost for the Database Administrator is less than that of the Assistant IT Manager funded in FY16, the residual funds would be put to use within other IT department operating budget line items.

A number of unbudgeted expenses for which there is very little contingency have recently emerged for which these residual funds would provide relief:

- Sales tax is now being applied to select software maintenance contracts which has raised the cost significantly on larger contracts.
- Battery replacements for three phase UPS systems in the 110 Vernon server room that would otherwise have to be deferred until the next fiscal year.
- Ancillary equipment costs incurred during the move and system integration into the new Metro Operations facility.

The above recommended actions would be cost neutral and would not require an amendment in the FY16 & FY17 IT department operating budget.

V. ALTERNATIVES CONSIDERED

- Leave the Assistant IT Manager position vacant. This is not recommended as we would miss an opportunity to add a much needed Database Administrator to the METRO IT Department.
- Fill the currently funded Assistant IT Manager position. METRO does not recommend this action because there is a greater need for a Database Administrator at this time.

VI. ATTACHMENTS

None

Prepared by: Isaac Holly, IT Manager

VII. APPROVALS:

Approved as to form:
Leslyn K. Syren, District Counsel



Approved as to fiscal impact:
Angela Aitken, Finance Manager



Alex Clifford, CEO/General Manager



- THIS PAGE INTENTIONALLY LEFT BLANK -